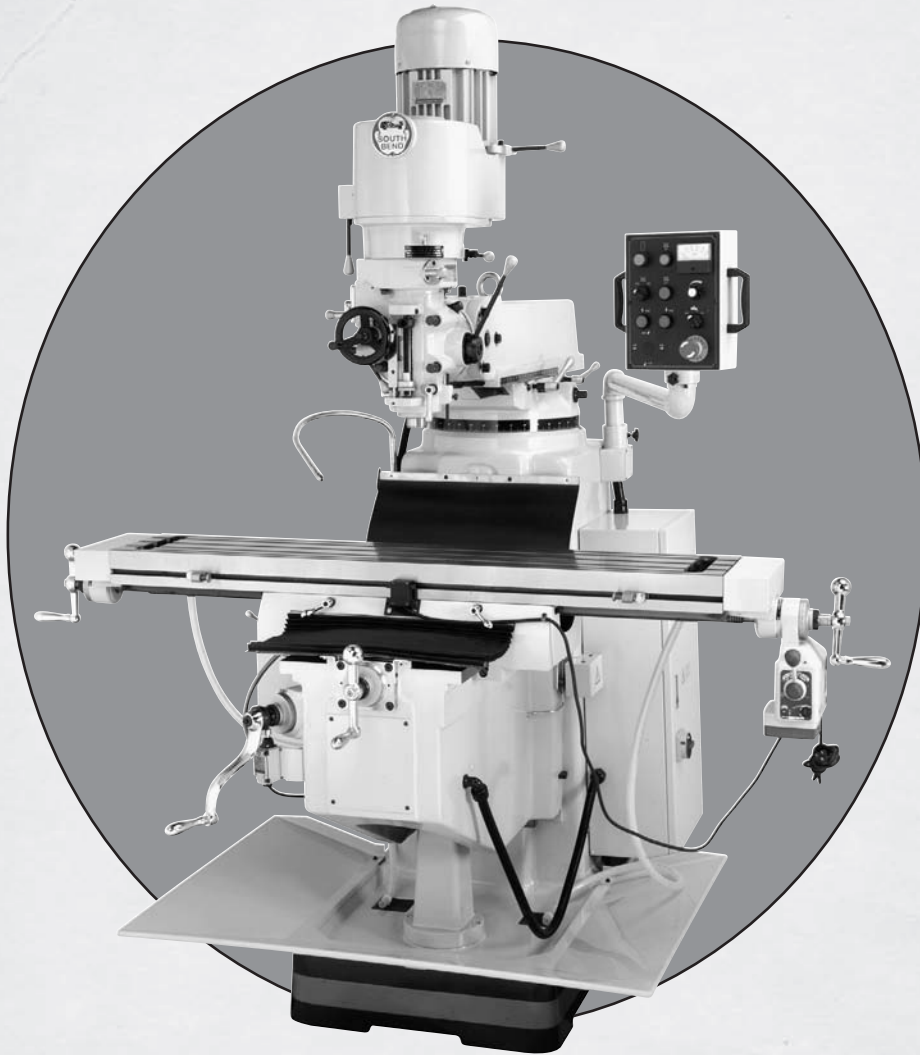




# 10" X 54" CHIPMASTER® 430 EVS VARIABLE-SPEED MILL MACHINE

MODEL SB1028



**OWNER'S MANUAL**

---

# South Bend Lathe Co.™

---

*Hundreds of Thousands of Lathes Sold With a Tradition of Quality Since 1906!*



# Scope of Manual

This manual helps the reader understand the machine, how to prepare it for operation, how to control it during operation, and how to keep it in good working condition. We assume the reader has a basic understanding of how to operate this type of machine, but that the reader is not familiar with the controls and adjustments of this specific model. As with all machinery of this nature, learning the nuances of operation is a process that happens through training and experience. If you are not an experienced operator of this type of machinery, read through this entire manual, then learn more from an experienced operator, schooling, or research before attempting operations. Following this advice will help you avoid serious personal injury and get the best results from your work.

## Manual Feedback

We've made every effort to be accurate when documenting this machine. However, errors sometimes happen or the machine design changes after the documentation process—so the manual may not exactly match your machine. If a difference between the manual and machine leaves you in doubt, contact our customer service for clarification.

We highly value customer feedback on our manuals. If you have a moment, please share your experience using this manual. What did you like about it? Is there anything you would change to make it better? Did it meet your expectations for clarity, professionalism, and ease-of-use?

**South Bend Lathe, Inc.**  
c/o Technical Documentation Manager  
P.O. Box 2027  
Bellingham, WA 98227  
Email: [manuals@southbendlathe.com](mailto:manuals@southbendlathe.com)

## Updates

For your convenience, any updates to this manual will be available to download free of charge through our website at:

[www.southbendlathe.com](http://www.southbendlathe.com)

## Customer Service

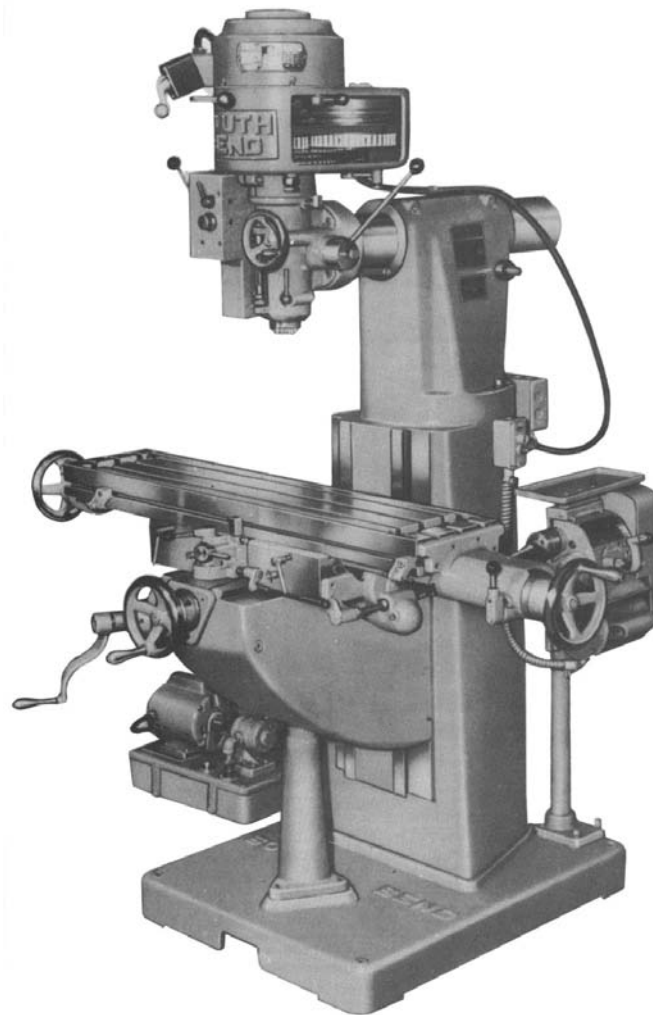
We stand behind our machines. If you have any service questions, parts requests or general questions about the machine, feel free to contact us.

**South Bend Lathe Co.**  
P.O. Box 2027  
Bellingham, WA 98227  
Phone: (360) 734-1540  
Parts Department: (417) 886-2954  
Fax: (360) 676-1075 (International)  
Fax: (360) 734-1639 (USA Only)  
Email: [cs@southbendlathe.com](mailto:cs@southbendlathe.com)

# Table of Contents

<b>INTRODUCTION.....</b>	<b>3</b>	Graduated Index Rings.....	30
About This Machine.....	3	X-Axis Power Feed.....	30
Foreword.....	3	Operating X-Axis Power Feed.....	31
Capabilities.....	3	Head Movement.....	32
Features.....	3	Tilting Head.....	32
Full View Identification.....	4	Rotating Head.....	33
Drive System & Headstock Identification.....	5	Tramming Spindle.....	33
Control Panel Identification.....	6	Ram Movement.....	36
Machine Specifications.....	7	Moving Ram Back and Forth.....	36
<b>SAFETY.....</b>	<b>10</b>	Rotating Ram.....	36
Understanding Risks of Machinery.....	10	Setting Spindle Speed.....	37
Basic Machine Safety.....	10	Determining Spindle Speed.....	37
Additional Milling Machine Safety.....	12	Setting Spindle Speed Range.....	37
<b>PREPARATION.....</b>	<b>13</b>	Setting Spindle Speed.....	38
Preparation Overview.....	13	Downfeed Controls.....	38
Required for Setup.....	13	Coarse Downfeed.....	38
Unpacking.....	14	Fine Downfeed Controls.....	40
Inventory.....	14	Fine Downfeed Handwheel.....	40
Cleaning & Protecting.....	15	Auto-Downfeed System.....	41
Location.....	16	Spindle Brake.....	42
Physical Environment.....	16	Loading/Unloading Tooling.....	43
Electrical Installation.....	16	Loading Tooling.....	43
Lighting.....	16	Unloading Tooling.....	43
Weight Load.....	16	<b>MAINTENANCE.....</b>	<b>44</b>
Space Allocation.....	16	Maintenance Schedule.....	44
Lifting & Moving.....	17	Ongoing.....	44
Leveling & Mounting.....	18	Before Beginning Operations.....	44
Leveling.....	18	Daily, After Operations.....	44
Bolting to Concrete Floors.....	18	Cleaning.....	46
Assembly.....	19	Unpainted & Machined Surfaces.....	46
Initial Lubrication.....	21	Lubrication.....	46
Power Requirements.....	21	Quill.....	47
Power Connection.....	22	Table Ways (One-Shot Oiler).....	47
Test Run.....	22	Speed Range Bearing Sleeve.....	48
Test Run the Mill.....	22	Headstock Gearing.....	48
Test Run X-Axis Power Feed.....	25	Ram Ways.....	48
Spindle Break-In.....	26	Head & Ram Rack & Pinion Gear.....	49
Inspections & Adjustments.....	26	Power Feed Gears.....	49
<b>OPERATION.....</b>	<b>27</b>	Coolant Reservoir.....	51
Operation Overview.....	27	Hazards.....	51
Control Panel.....	28	Checking Coolant Level.....	51
Table Movement.....	29	Changing Coolant.....	52
Table & Knee Locks.....	29	Machine Storage.....	53

<b>SERVICE.....</b>	<b>54</b>	<b>PARTS.....</b>	<b>69</b>
Adjusting Gibs.....	54	Headstock.....	69
Adjusting Leadscrew Backlash.....	55	Quill.....	72
X-Axis Leadscrew Backlash.....	55	Gearbox.....	73
Y-Axis Leadscrew Backlash.....	56	Belt Housing.....	75
Belt Tensioning.....	57	Ram.....	77
<b>TROUBLESHOOTING.....</b>	<b>58</b>	Column, Knee, & Saddle.....	78
<b>ELECTRICAL.....</b>	<b>60</b>	Table.....	80
Electrical Safety Instructions.....	60	One-Shot Oiler System.....	82
Wiring Overview.....	61	Coolant System.....	83
Upper Electrical Cabinet Wiring.....	62	Electrical Box & Control Panel.....	84
Electrical Cabinet Contactors Wiring.....	63	Tools.....	86
Lower Electrical Cabinet Wiring.....	64	Front Machine Labels.....	87
Control Panel, Spindle Motor, & Brake Switch		Side & Rear Machine Labels.....	88
Wiring.....	65	<b>WARRANTY &amp; RETURNS.....</b>	<b>89</b>
Other Electrical Components Wiring.....	66		
Electrical Component Pictures.....	67		



South Bend Vertical Spindle Precision Milling Machine  
(circa 1958)

# About This Machine

## Foreword

*"Most boys should learn a trade in order that they may become skilled workmen. The trained workman is always in demand...When a boy has learned a trade, becomes a skilled mechanic, he has excellent equipment with which to begin life's battle, but he need not stop there. George Westinghouse, the Wright Brothers, Henry Ford, and the Studebaker Brothers were mechanics, and it was their mechanical training that made their success possible."* —**Machine Shop Equipment**, 2nd Ed., 1920, by the O'Brien Brothers, founders of South Bend Lathe.

The first South Bend milling machine debuted in the 1950's. During that time, the milling machine and the already well-established South Bend lathes created the foundation of many tool rooms and school shops across America and beyond her borders. Many young people in those days came of age on South Bend equipment, becoming world-class machinists, mechanical engineers, inventors, and manufacturing visionaries.

A lot has changed in the world since then. Those same school shops have mostly been replaced by computer labs. The technology in the rotary dial phone, television set, mechanical calculator, computer, and camera of that decade could barely fit into one large room together—now they fit into a tiny box that is no bigger than a box of breath mints. And the average production machinist spends more time at a computer than at a machine. Technology has been much refined and the world operates on a much faster pace.

But some things haven't changed. The same human ingenuity and passion that created the best mechanical technology of today still exists within us. The core machines of the modern shop, like this South Bend milling machine, are still fundamentally important.

When you think about it, the greatest mechanical technology of the future will be what we create today. As the owner of a South Bend milling machine, you are now part of a great legacy. What will you create with yours?

## Capabilities

This Milling Machine is built for daily, non-stop use in a busy industrial setting, tool room, or school shop. It is easy to set-up, truly accurate, and built to give you many years of service when properly cared for. This milling machine supports large workpieces and is perfect for face milling, end milling, planing, slot or keyway cutting, dovetailing, routing, drilling, reaming, and boring to name a few. With the movable ram and tilting head, all these tasks can be performed on horizontal, vertical, and angled surfaces. When equipped with additional accessories, such as a rotary table or dividing head, this milling machine can do even more.

## Features

This milling machine features 3-axis table movement with built-in X-axis and Z-axis power feed. It is constructed with high-grade Meehanite castings, and the saddle and knee ways are Turcite coated and built with wide square ways for maximum support and accuracy through the full range of movement.

To ensure quality work results, we have equipped this mill with NSK/NTN spindle bearings that are rated to P4 (ABEC-7) tolerances. The spindle taper is R8 and has powered downfeed with fine, medium, and coarse feed controls.

The headstock is mounted on a wide dovetail movable ram with 19½" of travel on the column and 360° rotating capability. The headstock itself can swivel 90° left/right or 45° forward/back so it can be positioned for nearly any setup needed.

To reduce the time spent doing daily lubrication, this milling machine is outfitted with a one-shot lubrication system that is as quick and easy as one pump of a lever.

Quality Allen-Bradley electrical components and attention to detail provide dependable electrical control of the powered movements.

Last but not least, this milling machine includes a circulating coolant system with the pump and reservoir in the column base.

# Full View Identification

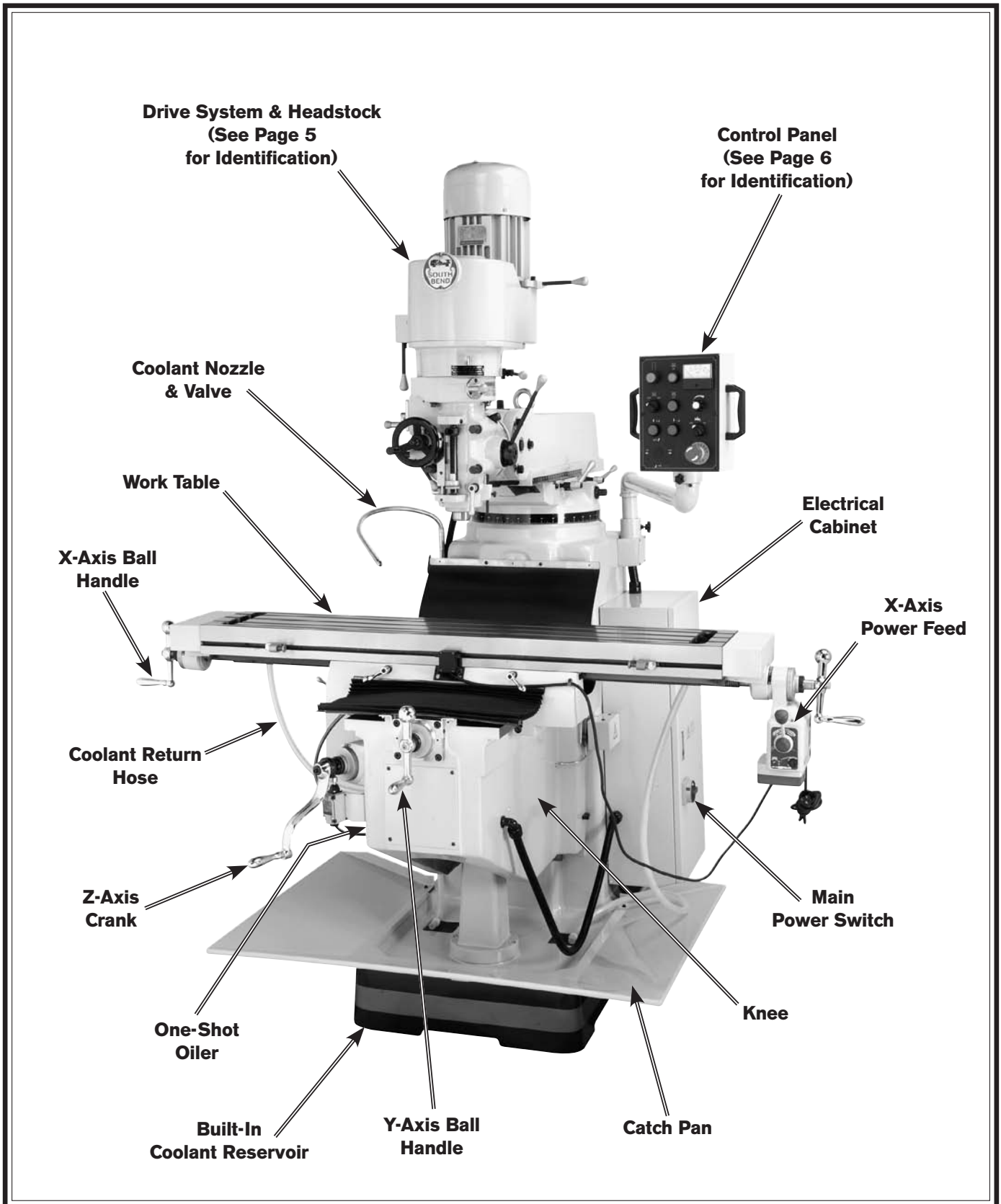


Figure 1. SB1028 full view identification.

# Drive System & Headstock Identification

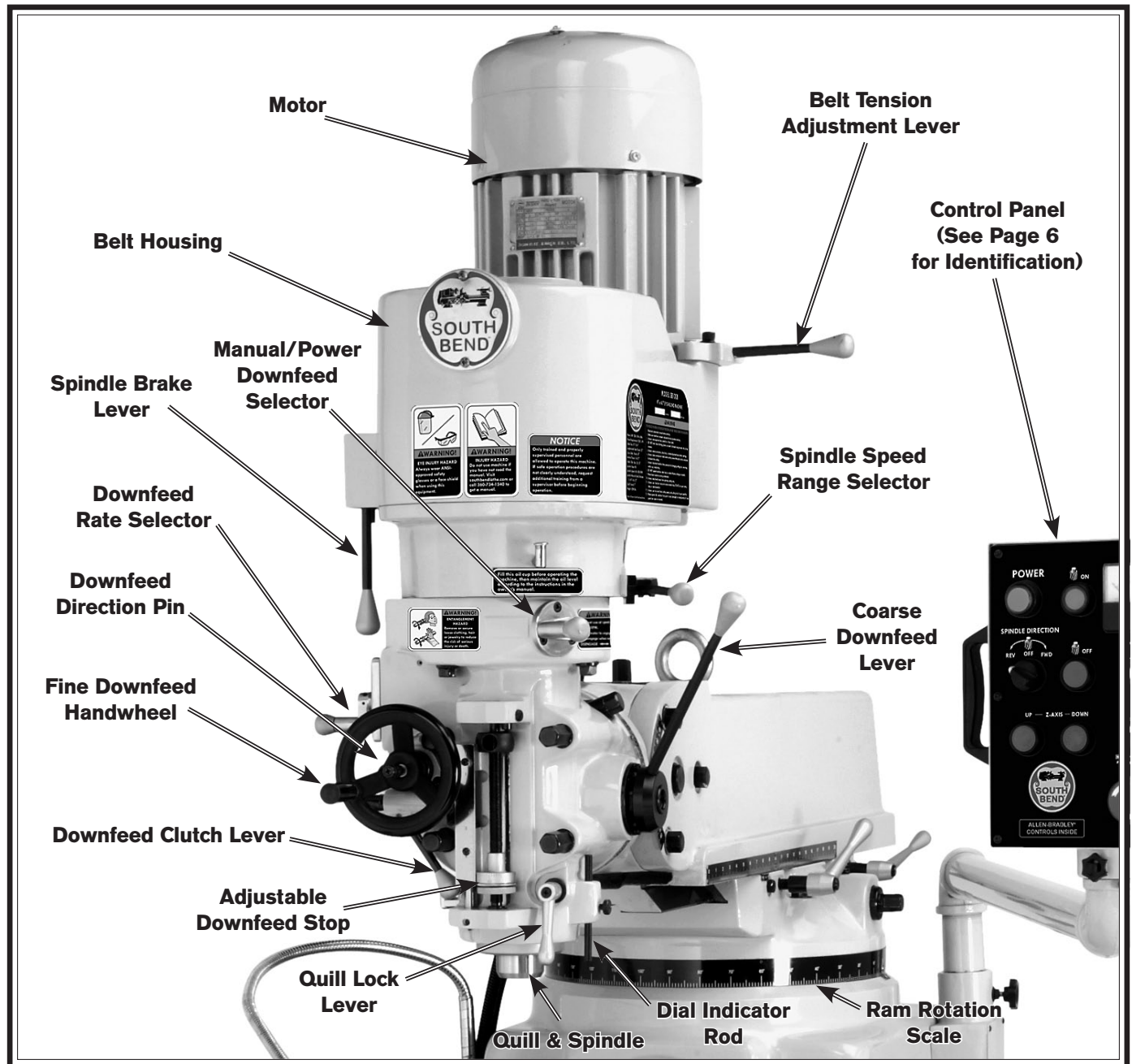


Figure 2. Model SB1028 drive system and headstock identification.

# Control Panel Identification

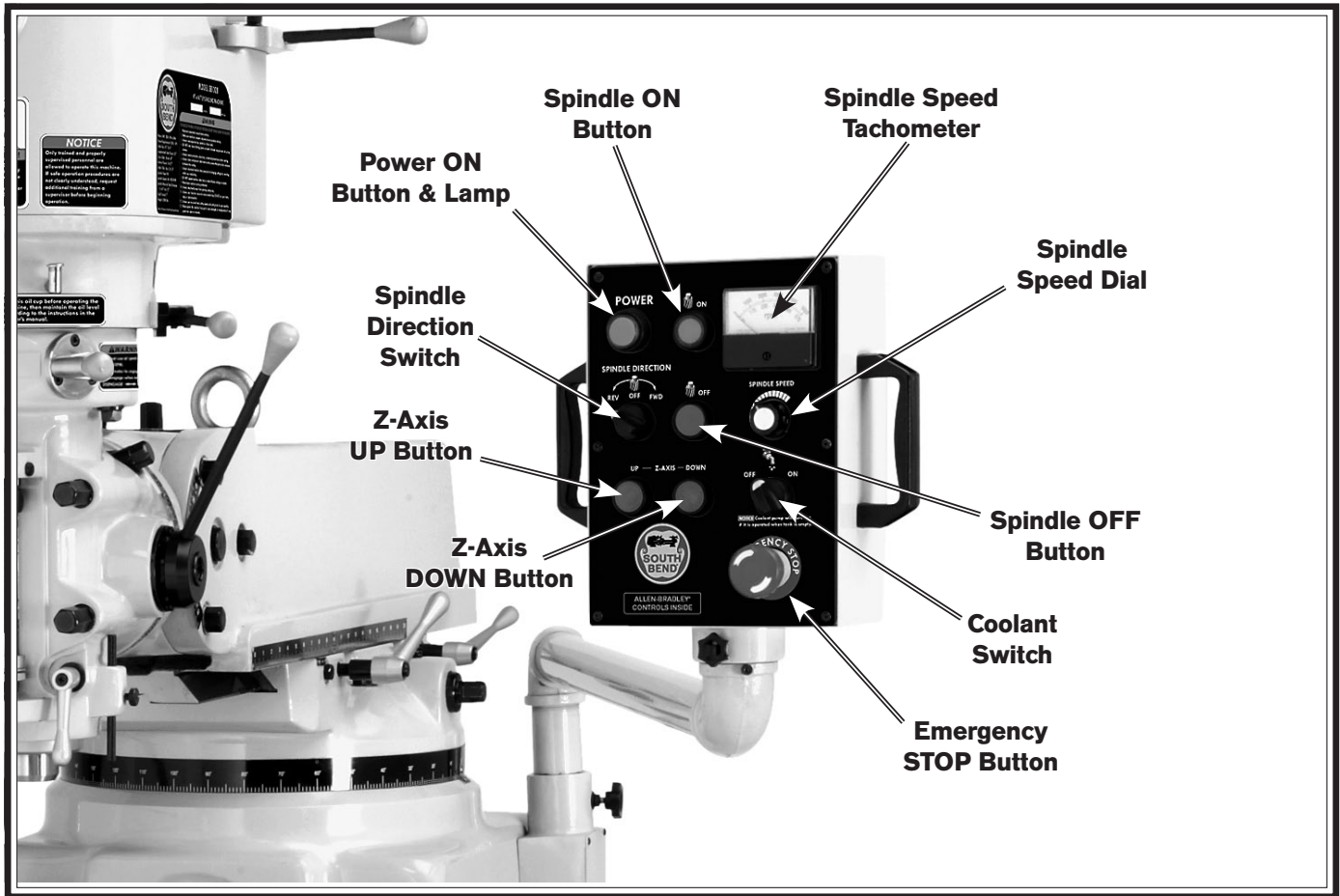


Figure 3. Model SB1028 control panel identification.

## **!WARNING**

Serious personal injury could occur if you connect the machine to power before completing the setup process. **DO NOT** connect power until instructed to do so later in this manual.

## **!WARNING**

Untrained users have an increased risk of seriously injuring themselves with this machine. Do not operate this machine until you have understood this entire manual and received proper training.



# Product Specifications

P.O. Box 2027, Bellingham, WA 98227 U.S.A.  
 PHONE: (360) 734-1540 • © South Bend Lathe Co.  
[www.southbendlathe.com](http://www.southbendlathe.com)



## Model SB1028 10" X 54" Chipmaster® 430 EVS Variable-Speed

### Product Dimensions

Weight..... 3000 lbs  
 Width (side-to-side) x Depth (front-to-back) x Height..... 66 x 77 x 89 in.  
 Footprint (Length x Width)..... 41-1/2 x 24-1/2 in.

### Shipping Dimensions

Type..... Wood Crate  
 Content..... Machine  
 Weight..... 3350 lbs.  
 Length x Width x Height..... 66 x 61 x 80 in.

### Electrical

Power Requirement..... 220V, Single-Phase, 60 Hz  
 Minimum Circuit Size..... 20A  
 Inverter Type..... Yaskawa VS-606V7  
 Inverter Size..... 7-1/3 HP (5.5 KW)  
 Switch..... ON/OFF Power Switch  
 Switch Voltage..... 220V  
 Plug Included..... No  
 Recommended Plug/Outlet Type..... NEMA 6-20

### Motors

#### Table Elevation Motor

Type..... TEFC Induction  
 Horsepower..... 1/4 HP  
 Voltage..... 220V  
 Phase..... Single-Phase  
 Amps..... 1.95A  
 Speed..... 170 RPM  
 Cycle..... 60 Hz  
 Power Transfer ..... Gearbox Drive  
 Bearings..... Lubricated & Shielded

#### Spindle Motor

Type..... AEVF Induction  
 Horsepower..... 5 HP  
 Voltage..... 220V  
 Phase..... 3-Phase  
 Amps..... 14A  
 Speed..... 1725 RPM  
 Cycle..... 60 Hz  
 Power Transfer ..... Belt Drive  
 Bearings..... Lubricated & Shielded

**Longitudinal Power Feed Motor**

Type.....	DC Universal
Horsepower.....	1/10 HP
Voltage.....	220V
Phase.....	Single-Phase
Amps.....	0.8A
Speed.....	0 — 200 RPM
Number of Speeds.....	Variable
Power Transfer .....	Belt Drive
Bearings.....	Lubricated & Shielded

**Coolant Pump Motor**

Type.....	Induction
Horsepower.....	1/8 HP
Voltage.....	220V
Phase.....	Single-Phase
Amps.....	0.45A
Speed.....	3450 RPM
Cycle.....	60 Hz
Power Transfer .....	Direct Drive
Bearings.....	Lubricated & Shielded

**Main Specifications**

**Operation Info**

Spindle Travel.....	5 in.
Longitudinal Table Travel.....	35 in.
Cross Table Travel.....	16 in.
Vertical Table Travel.....	14-1/4 in.
Ram Travel.....	19-1/2 in.
Head Swivel (Left-to-Right).....	90 Left, 90 Right deg.
Head Swivel (Front-to-Back).....	45 Forward, 45 Back deg.
Turret or Column Swivel (Left and Right).....	360 deg.
Maximum Distance Spindle to Column.....	6-1/2 — 26 in.
Maximum Distance Spindle to Table.....	2-1/4 — 16-1/2 in.
Number of Vertical Spindle Speeds.....	Variable
Range of Vertical Spindle Speeds.....	60 — 5000 RPM
Number of Longitudinal Feeds.....	Variable

**Table Info**

Table Length.....	54 in.
Table Width.....	10 in.
Table Thickness.....	3 in.
Number of T-Slots.....	3
T-Slots Width.....	5/8 in.
T-Slots Height.....	1-1/16 in.
T-Slots Centers.....	2-1/2 in.
Stud Size.....	1/2 in.

**Spindle Info**

Spindle Taper.....	R-8
Spindle Size.....	46 mm
End Milling Capacity.....	1 in.
Face Milling Capacity.....	4 in.
Drawbar Diameter.....	7/16 in.
Drawbar TPI.....	20 TPI
Drawbar Length.....	5-3/8 Head, 18 Shaft 23-3/8 Total (In.)
Spindle Bearings.....	Angular Contact, P4 (ABEC-7)

**Construction**

Table.....	Hardened & Precision-Ground Cast Iron
Head.....	Meehanite Cast Iron
Column.....	Meehanite Cast Iron
Paint.....	Urethane

**Other**

Country Of Origin .....	Taiwan
Warranty .....	1 Year
Serial Number Location .....	Machine ID Label on Right Side of Belt Housing
Assembly Time .....	2 Hours

**Features**

Allen-Bradley Electronic Components  
 High-Quality, Low-Vibration AEVF Spindle Motor  
 Built-In Single-Phase to 3-Phase Yasakawa Power Inverter  
 P4 (ABEC-7) High-Quality Angular Contact Spindle Bearings  
 X & Y Leadscrew Nuts Double-Bronzed for Ultra-Smooth Movement w/Minimal Backlash  
 Lever-Action One-Shot Pump Way Lubrication System  
 Control Panel Mounted on Adjustable Arm  
 Complete Built-In Coolant System  
 Table Elevation Power Feed (Z-Axis)  
 Variable Speed Longitudinal Power Feed (X-Axis)  
 Auto-Downfeed with Micro-Adjustable Stop  
 Hardened and Precision-Ground Table Surface  
 Chromed Steel Quill  
 Heavy-Duty Spindle Brake

# Understanding Risks of Machinery

Operating all machinery and machining equipment can be dangerous or relatively safe depending on how it is installed and maintained, and the operator's experience, common sense, risk awareness, working conditions, and use of personal protective equipment (safety glasses, respirators, etc.).

The owner of this machinery or equipment is ultimately responsible for its safe use. This responsibility includes proper installation in a safe environment, personnel training and usage authorization, regular inspection and maintenance, manual availability and comprehension, application of safety devices, integrity of cutting tools or accessories, and the usage of approved personal protective equipment by all operators and bystanders.

The manufacturer of this machinery or equipment will not be held liable for injury or property damage from negligence, improper training, machine modifications, or misuse. Failure to read, understand, and follow the manual and safety labels may result in serious personal injury, including amputation, broken bones, electrocution, or death.

The signals used in this manual to identify hazard levels are defined as follows:



*Death or catastrophic harm WILL occur.*



*Moderate injury or fire MAY occur.*



*Death or catastrophic harm COULD occur.*



*Machine or property damage may occur.*

## Basic Machine Safety

- 1. Owner's Manual:** All machinery and machining equipment presents serious injury hazards to untrained users. To reduce the risk of injury, anyone who uses THIS item MUST read and understand this entire manual before starting.
- 2. Personal Protective Equipment:** Operating or servicing this item may expose the user to flying debris, dust, smoke, dangerous chemicals, or loud noises. These hazards can result in eye injury, blindness, long-term respiratory damage, poisoning, cancer, reproductive harm or hearing loss. Reduce your risks from these hazards by wearing approved eye protection, respirator, gloves, or hearing protection.
- 3. Trained/Supervised Operators Only:** Untrained users can seriously injure themselves or bystanders. Only allow trained and properly supervised personnel to operate this item. Make sure safe operation instructions are clearly understood. If electrically powered, use padlocks and master switches, and remove start switch keys to prevent unauthorized use or accidental starting.
- 4. Guards/Covers:** Accidental contact with moving parts during operation may cause severe entanglement, impact, cutting, or crushing injuries. Reduce this risk by keeping any included guards/covers/doors installed, fully functional, and positioned for maximum protection.

- 5. Entanglement:** Loose clothing, gloves, neckties, jewelry or long hair may get caught in moving parts, causing entanglement, amputation, crushing, or strangulation. Reduce this risk by removing/securing these items so they cannot contact moving parts.
- 6. Mental Alertness:** Operating this item with reduced mental alertness increases the risk of accidental injury. Do not let a temporary influence or distraction lead to a permanent disability! Never operate when under the influence of drugs/alcohol, when tired, or otherwise distracted.
- 7. Safe Environment:** Operating electrically powered equipment in a wet environment may result in electrocution; operating near highly flammable materials may result in a fire or explosion. Only operate this item in a dry location that is free from flammable materials.
- 8. Electrical Connection:** With electrically powered equipment, improper connections to the power source may result in electrocution or fire. Always adhere to all electrical requirements and applicable codes when connecting to the power source. Have all work inspected by a qualified electrician to minimize risk.
- 9. Disconnect Power:** Adjusting or servicing electrically powered equipment while it is connected to the power source greatly increases the risk of injury from accidental startup. Always disconnect power **BEFORE** any service or adjustments, including changing blades or other tooling.
- 10. Secure Workpiece/Tooling:** Loose workpieces, cutting tools, or rotating spindles can become dangerous projectiles if not secured or if they hit another object during operation. Reduce the risk of this hazard by verifying that all fastening devices are properly secured and items attached to spindles have enough clearance to safely rotate.
- 11. Chuck Keys or Adjusting Tools:** Tools used to adjust spindles, chucks, or any moving/rotating parts will become dangerous projectiles if left in place when the machine is started. Reduce this risk by developing the habit of always removing these tools immediately after using them.
- 12. Work Area:** Clutter and dark shadows increase the risks of accidental injury. Only operate this item in a clean, non-glaring, and well-lighted work area.
- 13. Properly Functioning Equipment:** Poorly maintained, damaged, or malfunctioning equipment has higher risks of causing serious personal injury compared to those that are properly maintained. To reduce this risk, always maintain this item to the highest standards and promptly repair/service a damaged or malfunctioning component. Always follow the maintenance instructions included in this documentation.
- 14. Unattended Operation:** Electrically powered equipment that is left unattended while running cannot be controlled and is dangerous to bystanders. Always turn the power **OFF** before walking away.
- 15. Health Hazards:** Certain cutting fluids and lubricants, or dust/smoke created when cutting, may contain chemicals known to the State of California to cause cancer, respiratory problems, birth defects, or other reproductive harm. Minimize exposure to these chemicals by wearing approved personal protective equipment and operating in a well ventilated area.
- 16. Difficult Operations:** Attempting difficult operations with which you are unfamiliar increases the risk of injury. If you experience difficulties performing the intended operation, **STOP!** Seek an alternative method to accomplish the same task, ask a qualified expert how the operation should be performed, or contact our Technical Support for assistance.

## Additional Milling Machine Safety

- 1. Understanding Controls:** The mill is a complex machine that presents severe cutting or entanglement hazards if used incorrectly. Make sure you understand the use and operation of all controls before you begin milling.
- 2. Safety Accessories:** Flying chips or debris from the cutting operation can cause eye injury or blindness. Always use a chip guard in addition to your safety glasses or use a face shield when milling.
- 3. Work Holding:** Milling a workpiece that is not properly clamped to the table could cause the workpiece to fly into the operator with deadly force! Before starting the machine, be certain the workpiece has been properly clamped to the table. NEVER hold the workpiece by hand during operation.
- 4. Spindle Speed:** To avoid tool or workpiece breakage that could send flying debris at the operator and bystanders, use the correct spindle speed and feed rate for the operation. Allow the mill to gain full speed before beginning the cut.
- 5. Spindle Direction Change:** Changing spindle rotation direction while it is spinning could lead to gear damage or impact injury from broken tool or workpiece debris. ALWAYS make sure the spindle has completely stopped before changing spindle direction.
- 6. Stopping Spindle:** To reduce the risk of hand injuries or entanglement hazards, DO NOT attempt to stop the spindle with your hand or a tool. Allow the spindle to stop on its own or use the spindle brake.
- 7. Chip Cleanup:** Chips from the operation are sharp and hot and can cause cuts or burns. Using compressed air to clear chips could cause them to fly into your eyes and may drive them deep into the working parts of the machine. Use a brush or vacuum to clear away chips and debris from the machine or workpiece and NEVER clear chips while the spindle is turning.
- 8. Machine Care & Maintenance:** Operating the mill with excessively worn or damaged machine parts increases the risk of machine or workpiece breakage, which could eject hazardous debris at the operator. Operating a mill that is in poor condition will also reduce the quality of the results. To reduce this risk, maintain the mill in proper working condition by ALWAYS promptly performing routine inspections and maintenance.
- 9. Cutting Tool Usage:** Cutting tools have very sharp leading edges—handle them with care! Using cutting tools that are in good condition helps to ensure quality milling results and reduces the risk of personal injury from broken tool debris. Inspect cutting tools for sharpness, chips, or cracks before each use, and ALWAYS make sure the cutting tools are firmly held in place before starting the machine.

## Preparation Overview

The purpose of the preparation section is to help you prepare the machine for operation. Specific steps for each of these points will be covered in detail later in this section.

### The typical preparation process is as follows:

1. Unpack the machine and inventory the contents of the box/crate.
2. Clean the machine and its components.
3. Identify an acceptable location for the machine and move it to that location.
4. Safely moves the machine to its location.
5. Level the machine and either bolt it to the floor or place it on mounts.
6. Assemble the loose components and make any necessary adjustments or inspections to ensure the machine is ready for operation.
7. Connect the machine to the power source.
8. Test run the machine to make sure it functions properly and is ready for operation.
9. Perform the break-in procedure.

## Required for Setup

The items listed below are required to successfully set up and prepare this machine for operation.

### For Lifting

- A forklift or other power lifting device rated for at least 3500 lbs.
- Lifting chain and safety hook rated for at least 3500 lbs.
- Two lifting straps rated for at least 3500 lbs. each (refer to **Page 17** for details)

### For Power Connection

- A power source that meets the minimum circuit requirements for this machine. (Refer to **Page 21** for details.)
- A qualified electrician to ensure a safe and code-compliant connection to the power source`

### For Assembly

- Cotton rags
- Mineral spirits
- Safety glasses
- Oil can with any general machine oil
- Grease gun with any API GL 2 grease
- Stiff grease brush
- Floor mounting hardware as needed
- Combo wrench 1/2" or ratchet and 1/2" socket

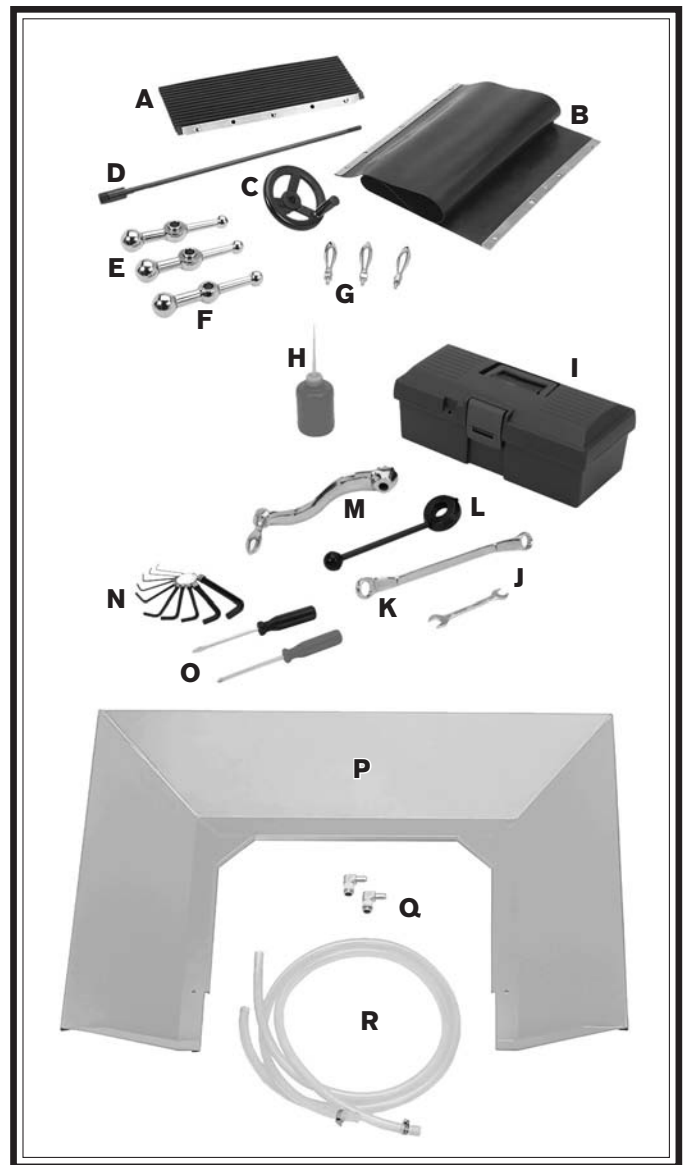
# Unpacking

This item was carefully packaged to prevent damage during transport. If you discover any damage, please immediately call Customer Service at (360) 734-1540 for advice. You may need to file a freight claim, so save the containers and all packing materials for possible inspection by the carrier or its agent.

# Inventory

After all of the parts, other than the mill, have been removed from the shipping crate, you should have the following inventory.

Description (Figure 4)	Qty
<b>A.</b> Front Way Cover.....	1
<b>B.</b> Rear Way Cover.....	1
<b>C.</b> Fine Downfeed Handwheel.....	1
<b>D.</b> Drawbar ½"-20 x 18½".....	1
<b>E.</b> Ball Handles (X-Axis).....	2
<b>F.</b> Ball Handle (Y-Axis).....	1
<b>G.</b> Ball Handle Handles.....	3
<b>H.</b> Oil Bottle.....	1
<b>I.</b> Tool Box.....	1
<b>J.</b> Combo Closed-End Wrench 19/21mm.....	1
<b>K.</b> Combo Open-End Wrench 12/14mm.....	1
<b>L.</b> Coarse Downfeed Lever.....	1
<b>M.</b> Z-Axis Crank.....	1
<b>N.</b> Hex Wrench 10 Pc. Set 1.5–10mm.....	1
<b>O.</b> Screwdrivers Slotted #2, Phillips #2....	1 Each
<b>P.</b> Catch Pan.....	1
<b>Q.</b> Coolant Return Hose Pipe Elbows.....	2
<b>R.</b> Coolant Return Hoses w/Clamps.....	2



**Figure 4. Shipping inventory.**

## Cleaning & Protecting

The unpainted surfaces are coated at the factory with a heavy-duty rust preventative that prevents corrosion during shipment and storage. The benefit of this rust preventative is that it works very well. The downside is that it can be time-consuming to thoroughly remove.

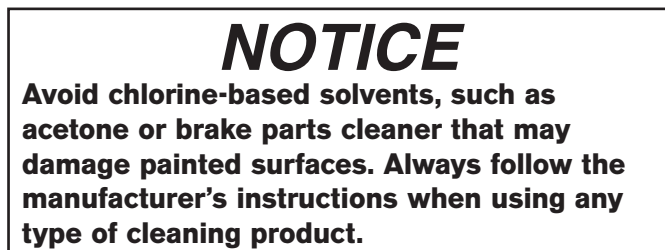
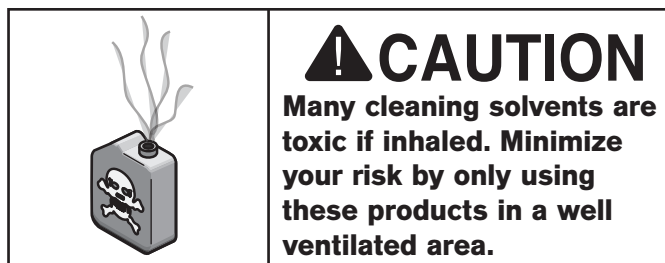
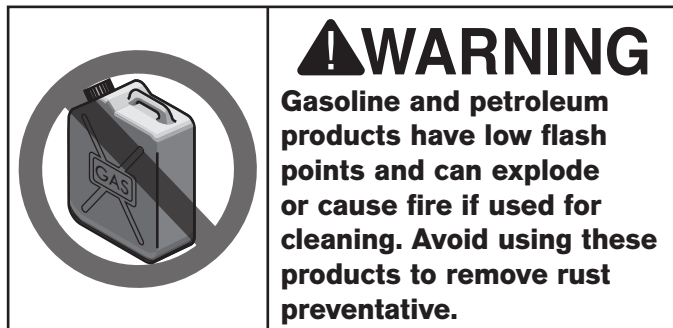
Be patient and do a careful job when cleaning and removing the rust preventative. The time you spend doing this will reward you with smooth-sliding parts and a better appreciation for the proper care of the unpainted surfaces.

Although there are many ways to successfully remove the rust preventative, we have cleaned thousands of machines and found the following process to be the best balance between efficiency and minimized exposure to toxic fumes or chemicals.

### Before cleaning, gather the following:

- Disposable rags
- Cleaner/degreaser (certain citrus-based degreasers work extremely well and they have non-toxic fumes)
- Safety glasses & disposable gloves

**Note:** Automotive degreasers, mineral spirits, or WD•40 can be used to remove rust preventative. Before using these products, though, test them on an inconspicuous area of a painted area to make sure they will not damage it.



### Basic steps for removing rust preventative:

1. Put on safety glasses and disposable gloves.
  2. Coat all surfaces that have rust preventative with a liberal amount of your cleaner or degreaser and let them soak for a few minutes.
  3. Wipe off the surfaces. If your cleaner or degreaser is effective, the rust preventative will wipe off easily.
- Note:** To clean off thick coats of rust preventative on flat surfaces, such as beds or tables, use a PLASTIC paint scraper to scrape off the majority of the coating before wiping it off with your rag. (Do not use a metal scraper or it may scratch the surface.)
4. Repeat **Steps 2–3** as necessary until clean, then coat all unpainted surfaces with a quality metal protectant or light oil to prevent rust.

# Location

## Physical Environment

The physical environment where your machine is operated is important for safe operation and longevity of parts. For best results, operate this machine in a dry environment that is free from excessive moisture, hazardous or flammable chemicals, airborne abrasives, or extreme conditions. Extreme conditions for this type of machinery are generally those where the ambient temperature is outside the range of 41°–104°F; the relative humidity is outside the range of 20–95% (non-condensing); or the environment is subject to vibration, shocks, or bumps.

## Electrical Installation

Place this machine near an existing power source. Make sure all power cords are protected from traffic, material handling, moisture, chemicals, or other hazards. Make sure to leave access to a means of disconnecting the power source or engaging a lockout/tagout device.

## Lighting

Lighting around the machine must be adequate enough that operations can be performed safely. Shadows, glare, or strobe effects that may distract or impede the operator must be eliminated.

## Weight Load

Refer to the **Machine Specifications** for the weight of your machine. Make sure that the surface upon which the machine is placed will bear the weight of the machine, additional equipment that may be installed on the machine, and the heaviest workpiece that will be used. Additionally, consider the weight of the operator and any dynamic loading that may occur when operating the machine.

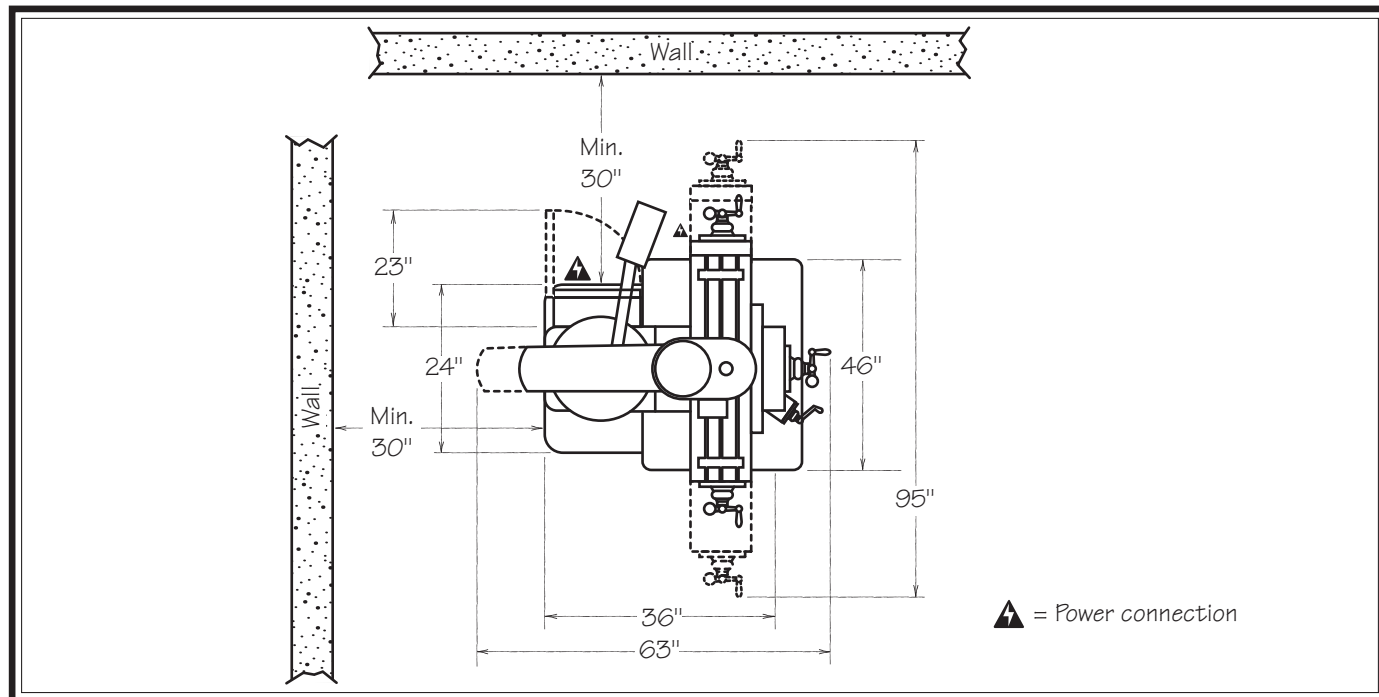
## Space Allocation

Consider the largest size of workpiece that will be processed through this machine and provide enough space around the machine for adequate operator material handling or the installation of auxiliary equipment. With permanent installations, leave enough space around the machine to open or remove doors/covers as required by the maintenance and service described in this manual.



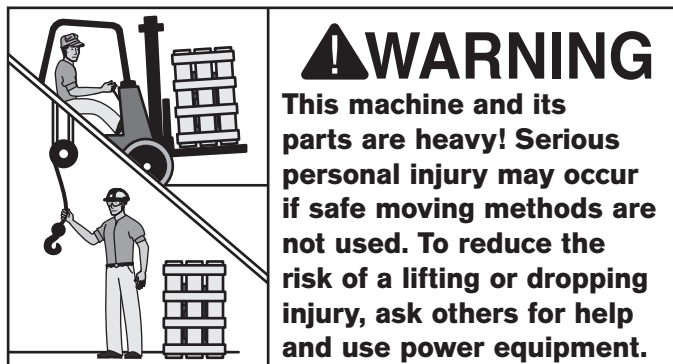
## **CAUTION**

**Children or untrained people may be seriously injured by this machine. Only install in an access restricted location.**



**Figure 5. Clearances.**

## Lifting & Moving



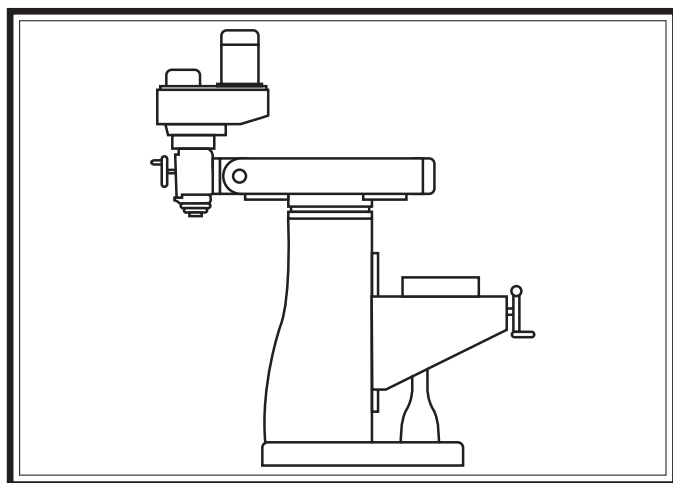
The method of lifting and moving the mill described below requires at least two other people for assistance and a forklift with two lifting web straps rated for at least 3500 lbs. each.

**Important:** Before lifting the mill, make sure the four turret lock bolts (two on each side of the ram) are torqued to 47 ft/lbs.

### To lift and move the mill:

1. Position the ram and headstock as illustrated in **Figure 6** (refer to **Ram Movement** on **Page 36** and **Headstock Movement** on **Page 32** for detailed instructions).

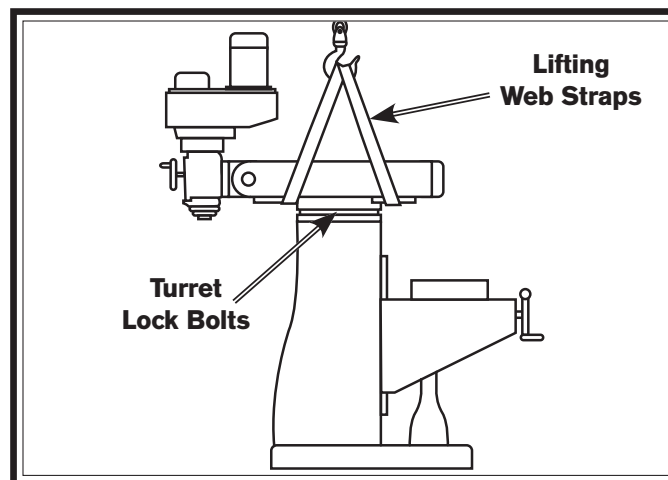
**Note:** After re-positioning the ram and headstock, make sure they are locked in place to prevent unexpected movement during lifting and moving.



**Figure 6. Ram and head position before moving.**

2. Place the lifting web straps under the ram and connect them to the forklift safety hook and chain, as illustrated in **Figure 7**.

**Note:** Place padding between the straps and the mill to protect the ram and ways, and to keep from cutting the lifting straps.



**Figure 7. Lifting the mill using web straps.**

3. Unbolt the mill from the shipping pallet.
4. With your assistants steadying the mill to keep it from swaying, lift the mill a couple of inches.
  - If the mill tips to one side, lower it to the ground and adjust the ram or table to balance the load. Make sure to re-tighten the lock levers and bolts before lifting the mill again.
  - If the mill lifts evenly, continue to move it to its permanent location.

## Leveling & Mounting

Although not required, we recommend that you level your machine and mount it to the floor. Because this is an optional step and floor materials may vary, mounting hardware is not included.

### **NOTICE**

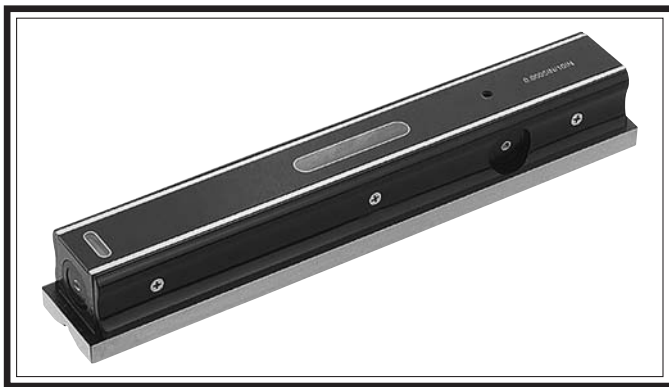
**We strongly recommend securing your machine to the floor if it is hardwired to the power source. Consult with your electrician to ensure compliance with local codes.**

### Leveling

Leveling machinery helps precision components, such as bed ways, remain straight and flat during the lifespan of the machine. Components on an unlevelled machine may slowly twist due to the dynamic loads placed on the machine during operation.

For best results, use a precision level that is at least 12" long and sensitive enough to show a distinct movement when a 0.003" shim (approximately the thickness of one sheet of standard newspaper) is placed under one end of the level.

See the figure below for an example of a high precision level.



**Figure 8. Example of a precision level.**

### Bolting to Concrete Floors

To prevent the Model SB1028 from tipping and causing a crushing hazard when heavy workpieces are mounted off-center, we strongly recommend that you bolt the mill to a concrete floor.

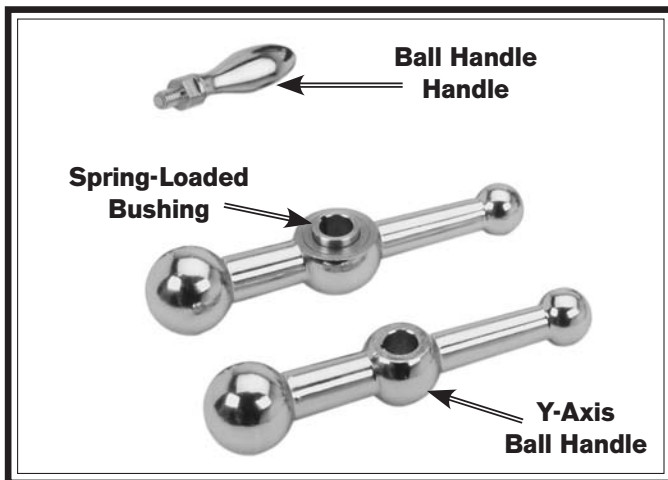
There are many different methods of securing the mill to the floor. Lag shield anchors and lag bolts are available in the sizes required for this mill. Also, cutting the floor and pouring footings with embedded J-bolts is another method.

We suggest you research the many options and methods for mounting the mill and choose the best that fits your specific application.

# Assembly

## To assemble the mill:

1. Remove the hex nuts from each end of the X-axis leadscrew.
2. Identify the two ball handles with the spring-loaded center bushings (see **Figure 9**).



**Figure 9. Ball handle assemblies.**

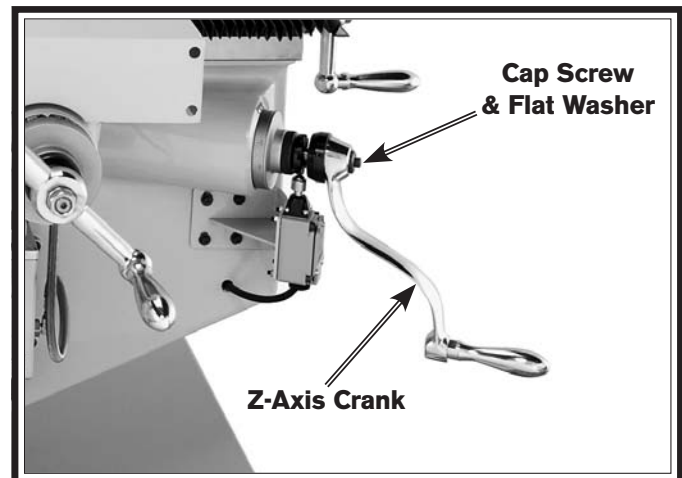
3. Position each ball handle so that the protruding part of the center bushing is facing toward the table, align the keyway with the leadscrew key, then slide it onto the X-axis leadscrew.
4. Secure the ball handles with the hex nuts removed in **Step 1**.

**Note:** Tighten the hex nuts just until they are snug. Overtightening could increase the wear of the moving parts.

5. Remove the hex nut from the Y-axis leadscrew.
6. Align the ball handle keyway with the leadscrew key, slide the Y-axis ball handle (see **Figure 9**) onto the leadscrew, then secure it in place with the removed hex nut.
7. Thread the handles into the small end of the ball handles and tighten them with a wrench.

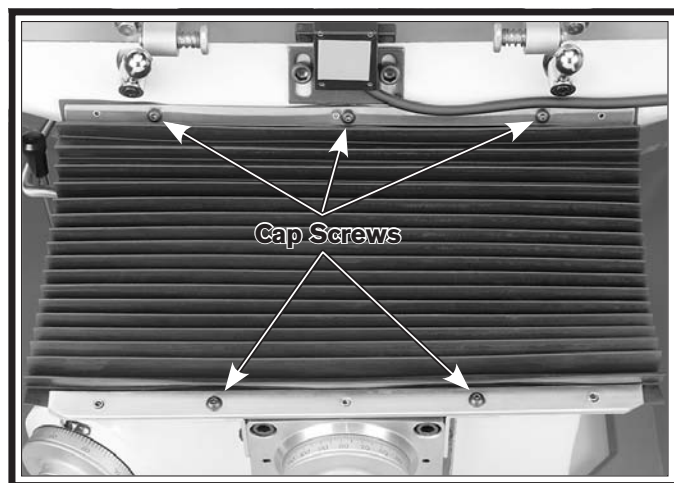
**Note:** The Z-axis crank is spring-loaded so that the teeth of the crank and the leadscrew do not remain engaged. This is a safety feature that prevents the crank from rapidly rotating when the Z-axis power feed is used.

8. Remove the cap screw and flat washer from the end of the Z-axis leadscrew, slide the crank on, then reinstall the cap screw and flat washer, as shown in **Figure 10**.



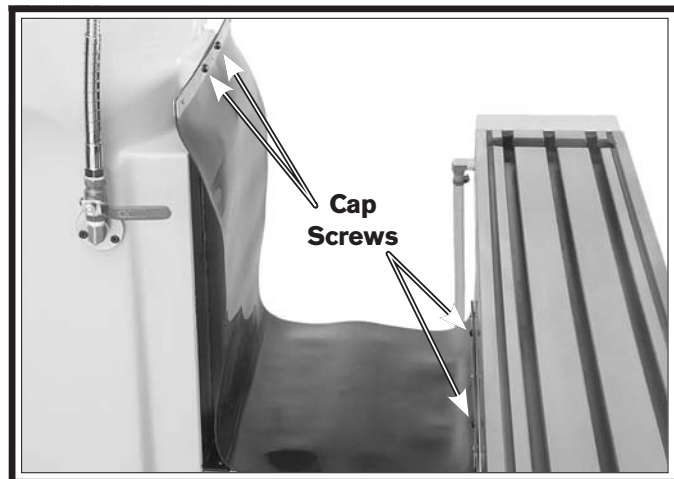
**Figure 10. Z-axis crank installed.**

9. Remove the five button-head cap screws shown in **Figure 11** from the front of the saddle and knee, position the pleated way cover in place, then secure it with the removed cap screws.



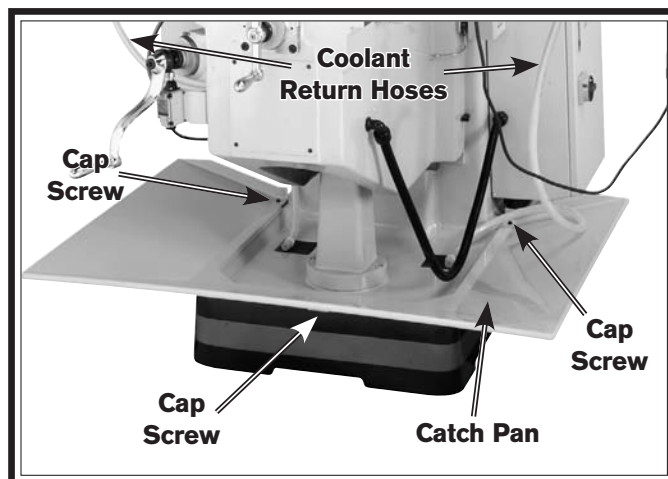
**Figure 11. Front way cover installed.**

10. Remove the four button-head cap screws shown in **Figure 12** from the column and the rear of the table, position the rear way cover in place, then secure it with the removed cap screws.



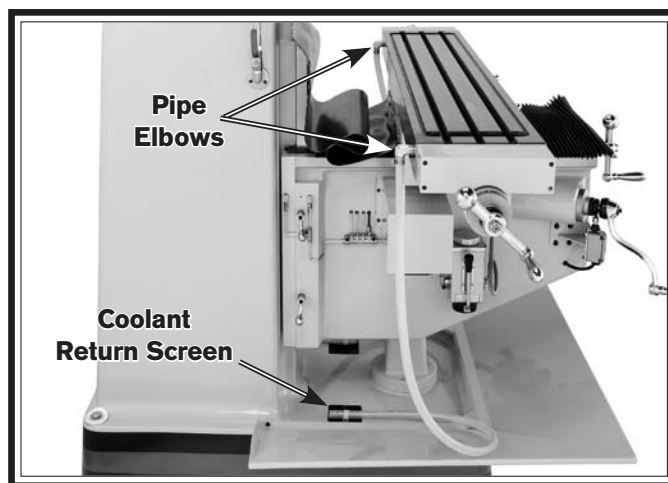
**Figure 12. Rear way cover installed.**

11. Remove the three cap screws shown in **Figure 13** from the base rim, slide the catch pan into position, then secure it with the removed cap screws.



**Figure 13. Catch pan and coolant return hoses installed.**

12. Use Teflon tape or pipe sealant on the threads of the pipe elbows, then thread them into the coolant drain holes located on both ends of the table, as shown in **Figure 14**.

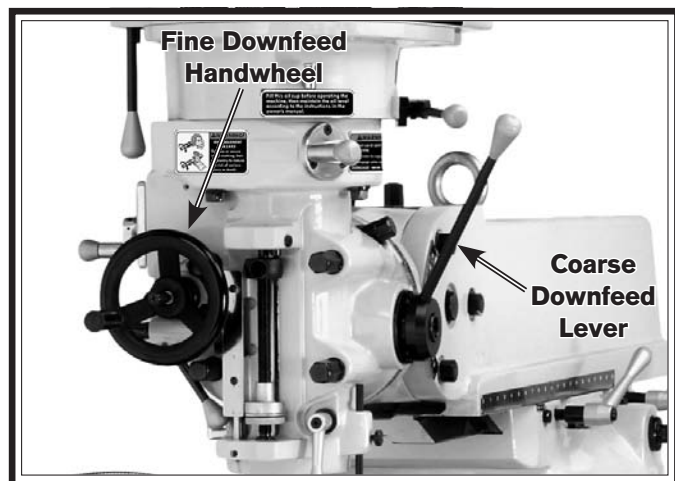


**Figure 14. Coolant return hose connections.**

13. Loosen the hose clamps on the end of the coolant return hoses, push the hoses onto the pipe elbows, then re-tighten the clamps.
14. Tug the hoses to make sure they are firmly attached to the pipe elbow. If they are loose, repeat **Step 13**.

15. Loosen the hose clamp screws above the coolant return screens in the base (see **Figure 14** on the previous page), insert the hoses so that they will drain into the screens, then re-tighten the clamp screws to secure them in place.
16. Install the coarse downfeed lever and the fine downfeed handwheel, as shown in **Figure 15**.

**Note:** Make sure the pins on the back of these devices are fully seated in the hubs before use.



**Figure 15.** Coarse downfeed lever and fine downfeed handwheel installed.

## Initial Lubrication

The machine was lubricated at the factory, but we strongly recommend that you inspect all lubrication points yourself and provide additional lubrication if necessary. Refer to **Lubrication on Page 46** for specific details.

## Power Requirements

	<p><b>!WARNING</b></p> <p><b>Electrocution or fire may occur if machine is ungrounded, incorrectly connected to power, or connected to an undersized circuit. Use a qualified electrician to ensure a safe power connection.</b></p>
--	--

Once the machine is set up and assembled as previously described in this manual, it is ready to be connected to the power source.

**Note About Required Power Source:** The milling machine is equipped with a Yaskawa phase inverter that changes single-phase power into 3-phase which is used by the spindle motor.

**Note About Extension Cords:** Using an incorrectly sized extension cord may decrease the life of electrical components on the machine.

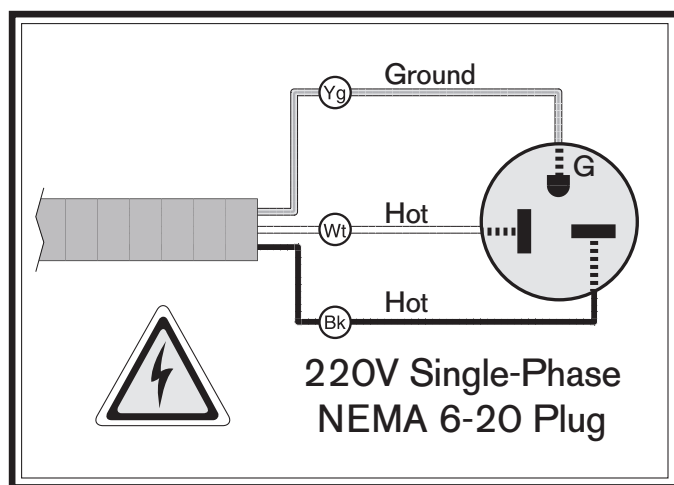
Required Power Source.....	220V, Single-Phase
Full Load Amp Draw .....	17.25 Amps
Nominal Voltage Range .....	220V/240V
Frequency .....	60 Hz
Minimum Circuit Size .....	20 Amps
Power Cord .....	12 AWG/3C/300VAC, "S" Type
Plug/Receptacle .....	NEMA 6-20
Minimum Extension Cord Size .....	12 AWG
Maximum Extension Cord Length.....	50 ft.

<p><b>NOTICE</b></p> <p><b>There are a series of steps that must be followed to when turning the machine ON. Before connecting the machine to power as instructed on the next page, make sure the main power switch located on the electrical box remains OFF. This will disable power to the control panel until it is required in the Test Run on Page 22.</b></p>
--

## Power Connection

1. Make sure the incoming power source meets the requirements stated in **Power Requirements** on the previous page.
2. We recommend that you attach a NEMA 6-20 plug to the included power cord to be used with the corresponding receptacle.

**Note:** Follow the manufacturer's wiring instructions included with the NEMA 6-20 plug. If these instructions are not provided, refer to the illustration in **Figure 16** or consult with a qualified electrician.



**Figure 16.** NEMA 6-20 plug wired to the included power cord.

## Grounding Instructions

In the event of certain types of malfunctions or breakdowns, grounding provides a safe path of least resistance for electric current—in order to reduce the risk of electric shock.

The power cord and plug specified under **Power Requirements** on the previous page have an equipment-grounding wire and grounding prong. The plug must only be inserted into a matching receptacle (outlet) that is properly installed and grounded in accordance with all local codes and ordinances.

## Test Run

	<p><b>NOTICE</b></p> <p><b>Pulling the power plug from the receptacle while the mill is running could damage the power inverter inside the electrical box or other electrical components. Always use the emergency STOP button, main power switch, or the circuit breaker to turn the mill OFF before pulling the plug.</b></p>
--	---

After all preparation steps have been completed, the machine and its safety features must be tested to ensure correct operation.

If you discover a problem with the operation of the machine or its safety components, do not operate it further until you have resolved the problem. Refer to the **Troubleshooting** section on **Page 58** for solutions to common problems that may occur with all mills. If you need additional help, contact our Tech Support at (360) 734-1540.

During the test run, you will verify the proper operation of the following:

- Spindle motor
- Emergency STOP button
- Electrical cabinet safety switch
- Spindle brake
- Coolant pump
- Z-axis power feed
- X-axis power feed

## Test Run the Mill

1. Read and follow the safety instructions at the beginning of the manual, take the required safety precautions, and make sure the machine is set up and adjusted properly.

## NOTICE

Operating the coolant pump of this mill without the correct amount of coolant in the reservoir could damage the mill and void the warranty. **ALWAYS** make sure there is the correct amount of coolant in the reservoir before using the pump.

2. Clean out the coolant reservoir in the base of the mill, then fill it with coolant (refer to the **Coolant Reservoir** section on **Pages 51–52** for specific details).
3. Clear away all tools and objects used during assembly and preparation.
4. Rotate the spindle speed dial on the control panel counterclockwise to the lowest setting, the spindle direction switch to the OFF (middle) position, and the coolant switch to the OFF (left) position (see **Figure 17**). This will disable these functions for now when the power initially flows to the control panel in the next steps.

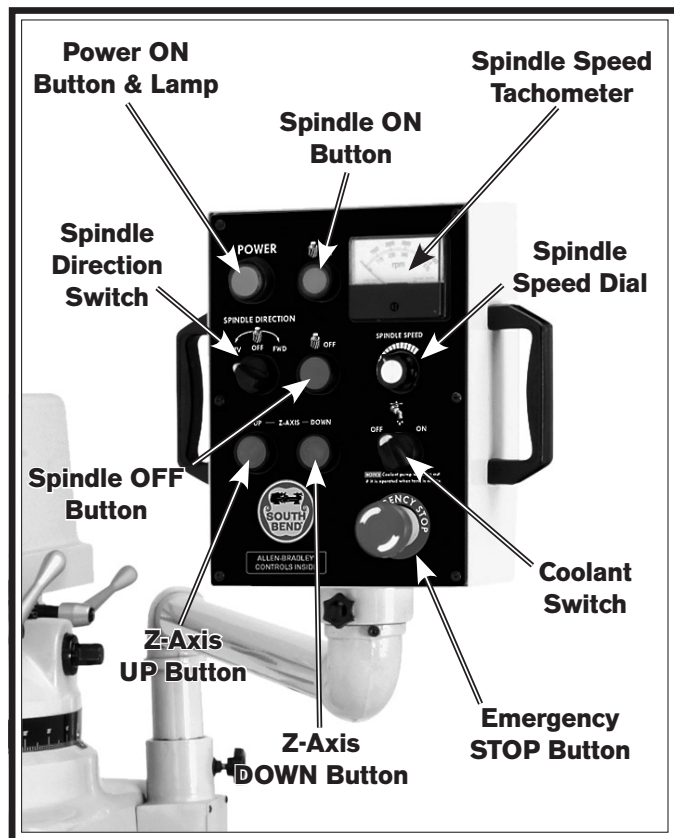


Figure 17. Control panel identification.

5. Set the spindle speed to the low range (refer to the **Setting Spindle Speed Range** section beginning on **Page 37** for detailed instructions).
6. Move the downfeed selector to the manual (forward) position so that the spindle does not feed into the table during this test (refer to the **Downfeed Controls** section on **Page 38** for detailed instructions).
7. Make sure the electrical cabinet door is latched shut, then rotate the main power switch to the **ON** position so that power flows to the control panel (see **Figure 18**).

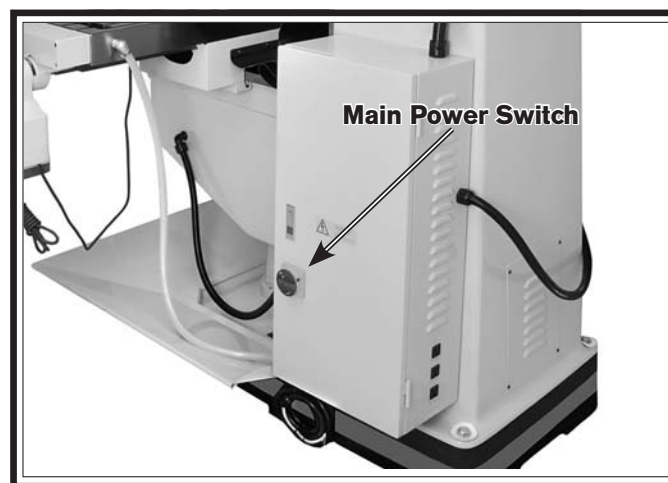


Figure 18. Location of main power switch on the electrical box door.

8. Push the emergency STOP button in, then twist it clockwise until it pops out. When the switch pops out, the mill is ready for operation.
9. Press the power ON button to enable power to the control panel and illuminate this button.

- 10.** Press the spindle ON button, then turn the spindle direction switch to the forward (right) position to start spindle rotation.
- 11.** Listen for abnormal noises and watch for unexpected actions or operation. The mill should run smoothly and without excessive vibration or rubbing noises.
  - Strange or unusual noises or actions must be investigated immediately. Press the emergency STOP button to turn the machine **OFF** and disconnect it from the power source before investigating or correcting potential problems.
- 12.** Press the emergency STOP button to turn the machine **OFF**, then wait for the spindle to stop on its own.
- 13.** WITHOUT resetting the emergency STOP button, press the power ON button, then attempt to start spindle rotation by using the spindle ON button and the spindle direction switch.
  - If the machine does not start, the emergency STOP button safety feature is working correctly.
  - If the machine does start (with the emergency STOP button pushed in), immediately disconnect power to the machine. The emergency STOP button safety feature is not working correctly. This safety feature must work properly before proceeding with regular operations. Call Tech Support for help.
- 14.** Reset the emergency STOP button, turn the main power switch on the electrical cabinet door to the OFF position, then press the ON button. Again, the machine should not start.
  - If the machine does not start, the main power switch safety feature is working correctly.
  - If the machine does start (with the main power switch turned to the OFF position), immediately turn the mill **OFF** and disconnect power to the machine. The main power switch safety feature is not working correctly. This safety feature must work properly before proceeding with regular operations. Call Tech Support for help.
- 15.** Make sure the emergency STOP button has been reset and the main power switch turned to the ON position, then press the ON button to start spindle rotation.
- 16.** Push the spindle brake lever—the spindle motor should turn **OFF** and the spindle should quickly stop.
- 17.** Position the coolant nozzle over the table, turn the coolant switch **ON** to start the coolant pump, then open the valve at the base of the nozzle to begin the flow of coolant.
- 18.** Check for leaks from the hose fittings and make sure that the coolant is properly draining back into the reservoir through the screens on the base.

19. Use the Z-axis UP and DOWN buttons on the control panel to verify that the table moves in the selected direction.

## Test Run X-Axis Power Feed

The mill comes with a power feed unit for X-axis table travel. Proper operation of the limit switch attached to the front of the table is critical for the safe use of this power feed unit.

If the power feed does not operate as expected during the following steps, disconnect it from power and contact our Tech Support at (360) 734-1540 for assistance.

### To test run the X-axis power feed:

1. Make sure all tools, cables, and other items are well clear of table movement as you follow these steps.
2. Refer to the **Table Movement** section, beginning on **Page 29**, to understand how the power feed, table locks, and limit switch function.
3. Loosen the table locks on the front of the table.
4. Plug the power feed power cord into a 110V power outlet.

**Note:** There are 110V outlets on the right side of the electrical cabinet that can be used for the power feed.

5. Make sure the power feed directional lever is in the neutral (middle) position, turn the speed dial counterclockwise to the lowest setting, then flip the power switch to the ON (up) position.

6. Turn the directional lever to the left, slowly turn the speed dial clockwise to increase the speed and confirm that the table is moving to the left.
7. Allow the table limit stop to hit the limit switch and turn the power feed **OFF**, which will stop table movement.
8. Turn the directional lever through the neutral (middle) position and all the way to the right. The table should begin moving to the right.
9. Confirm that the table stops moving when the limit stop presses against the limit switch plunger.
10. Move the directional lever to the neutral (middle) position and flip the power switch to the OFF (down) position.

Congratulations! The **Test Run** is complete. Continue with the next page to perform the **Spindle Break-In and Inspections & Adjustments** procedures.

# Spindle Break-In

## **NOTICE**

**Complete the spindle bearing break-in procedure to avoid rapid deterioration of spindle components when the mill is placed into operation.**

The high-quality bearings and gears used in the mill are manufactured to very close tolerances. Before subjecting the mill to full loads, you must break it in. Bearings will fully seat, gear teeth will find their normal wear pattern, and lubricant will be worked into the required areas.

### **To perform the spindle break-in procedure:**

1. Successfully perform all the steps in the **Test Run** section beginning on **Page 22**.
2. Make sure the spindle is completely stopped.
3. Set the spindle speed to the low range (refer to **Setting Spindle Speed** beginning on **Page 37** for detailed instructions).
4. Start the spindle rotation at a medium speed and let the mill run for 20 minutes.
5. Stop the spindle and allow the spindle to completely stop.
6. Set the spindle speed to the high range, then start the spindle at a medium speed and let the mill run for another 20 minutes.
7. Stop the spindle, and turn the mill **OFF**.

The spindle break-in is now complete!

## **NOTICE**

**Since the mill head was rotated parallel to the table for shipping purposes, you will need to tram the spindle with the table if your first operation requires 90° alignment. Refer to the Trimming Spindle section on Page 33 for detailed instructions.**

# Inspections & Adjustments

The following list of adjustments were performed at the factory before the machine was shipped:

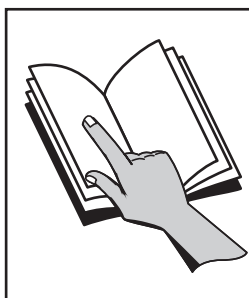
- Gib Adjustment .....**Page 54**
- Leadscrew Backlash Adjustment.....**Page 55**

Be aware that machine components can shift during the shipping process. Pay careful attention to the adjustments above during operation of the machine. If you find that the adjustments are not set according to the procedures in this manual or your personal preferences, re-adjust them.

## Operation Overview

The purpose of this overview is to provide the novice machine operator with a basic understanding of how the machine is used during operation, so they can more easily understand the controls discussed later in this manual.

**Note:** Due to the generic nature of this overview, it is not intended to be an instructional guide for performing actual machine operations. To learn more about specific operations and machining techniques, seek training from people experienced with this type of machine, and do additional research outside of this manual by reading "how-to" books, trade magazines, or websites.

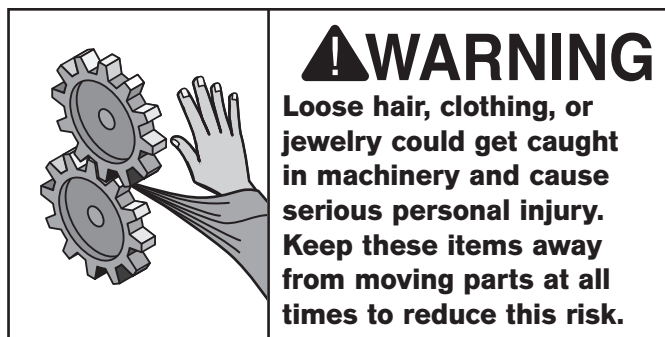


### **!WARNING**

To reduce the risk of serious injury when using this machine, read and understand this entire manual before beginning any operations.

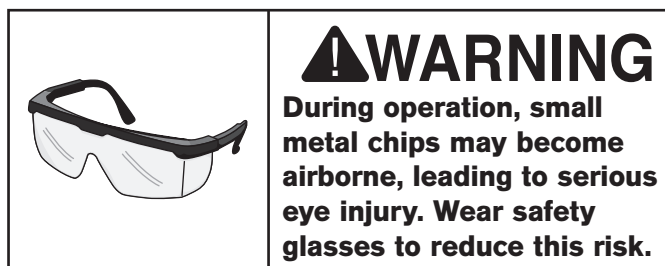
**In a typical milling operation, the operator does the following:**

1. Examines the workpiece to make sure it is suitable for milling.
2. Firmly clamps the workpiece to the table.
3. Installs the correct cutting tool for the operation.
4. Uses the manual downfeed and table controls to confirm the correct positioning of the cutting tool and workpiece for the operation. If the X-axis or Z-axis power feed will be used during the operation, the operator confirms the speed and length of table movement required.



### **!WARNING**

Loose hair, clothing, or jewelry could get caught in machinery and cause serious personal injury. Keep these items away from moving parts at all times to reduce this risk.



### **!WARNING**

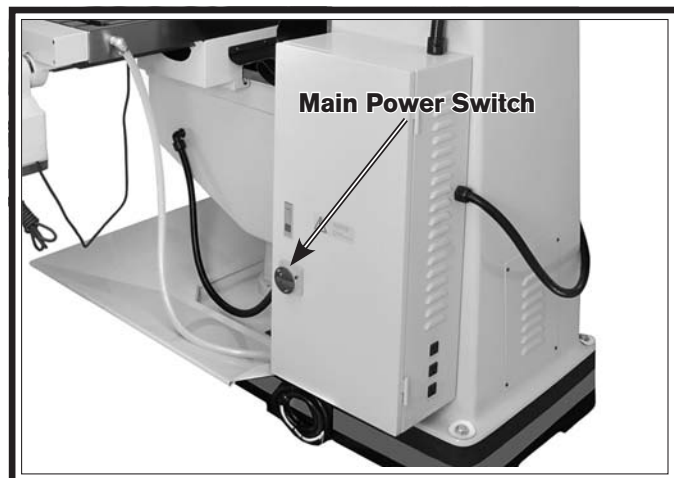
During operation, small metal chips may become airborne, leading to serious eye injury. Wear safety glasses to reduce this risk.

5. Configures the mill for the correct spindle speed of the operation.
6. Puts on personal protective gear and makes sure the workpiece and table are clear of all tools, cords, and other items.
7. Starts the spindle rotation and performs the operation.
8. Turns the mill **OFF**.

## Control Panel

Use **Figures 19–20** and the following descriptions to understand the functions of the mill main power switch and the control panel.

**Main Power Switch:** When turned *ON*, enables power to the control panel.



**Figure 19.** Location of the main power switch on the electrical box door.

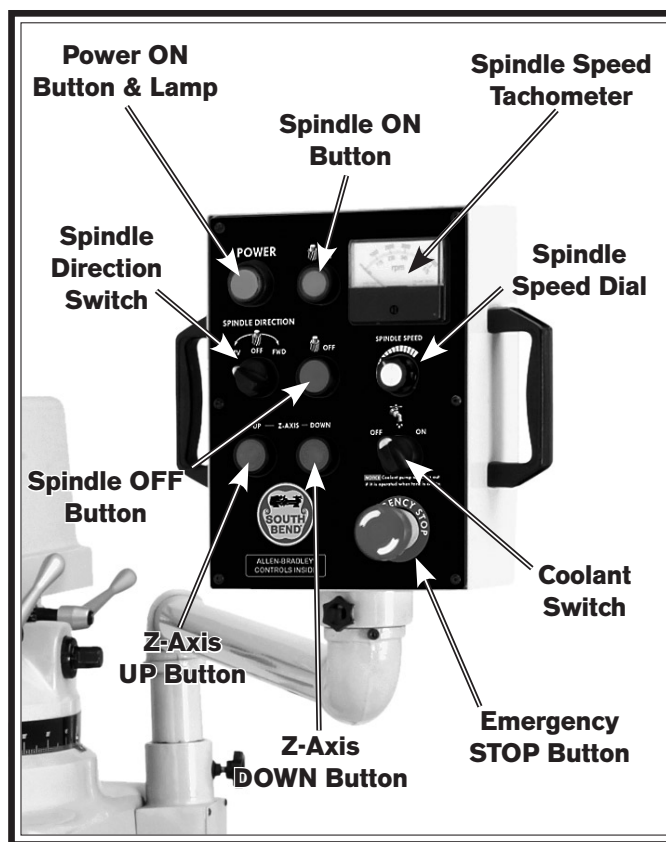
**Power ON Button & Lamp:** When pressed, illuminates and enables power to the other functions of the control panel.

**Spindle ON Button:** Starts spindle rotation.

**Spindle Speed Tachometer:** Displays the current spindle rotation speed.

**Spindle Speed Dial:** Controls the spindle speed within the selected spindle speed range.

**Coolant Switch:** Controls the coolant pump.



**Figure 20.** Control panel identification.

**Emergency STOP Button:** Disables power to all other functions on the control panel; i.e., spindle, coolant pump, and Z-axis power feed.

**Z-Axis DOWN Button:** Moves the knee and table down.

**Z-Axis UP Button:** Moves the knee and table up.

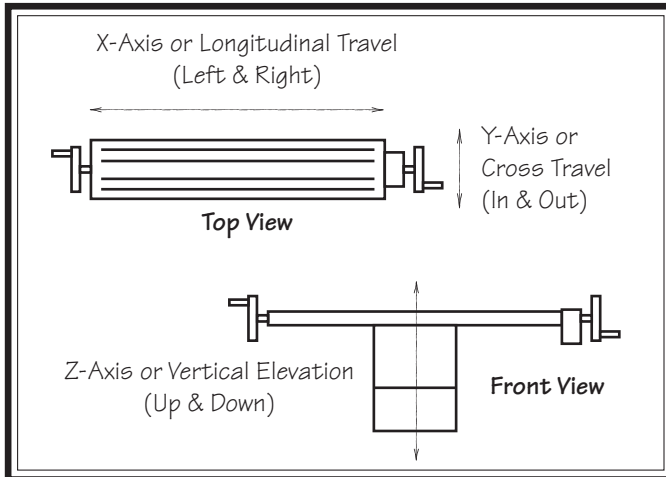
**Spindle OFF Button:** Stops the spindle motor.

**Spindle Direction Switch:** Controls the direction of spindle rotation.

## Table Movement

The mill table moves in three directions, as illustrated in **Figure 21**:

- X-axis
- Y-axis
- Z-axis



**Figure 21. The directions of table movement.**

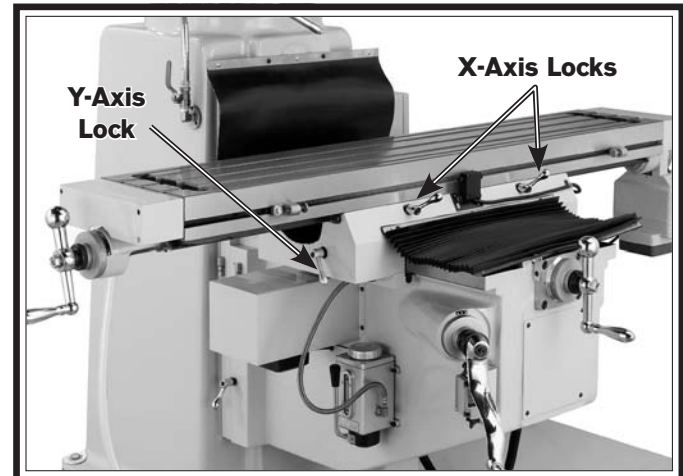
These movements are controlled by table ball handles and the Z-axis crank. Additionally, the table can be moved along the X- and Z-axes with the power feeds.

### **NOTICE**

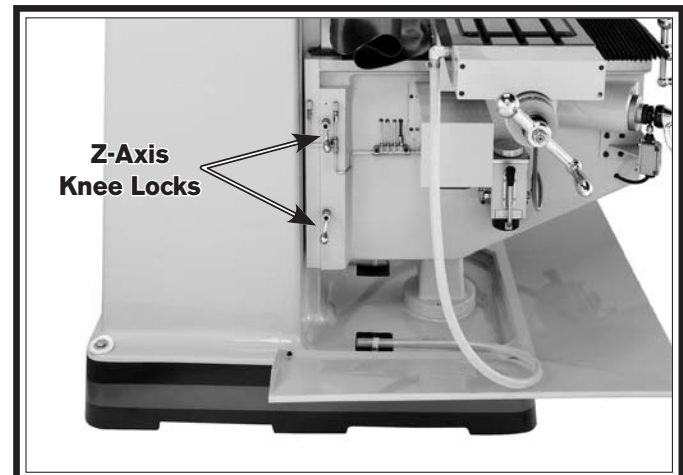
**Always keep the table locked in place unless table movement is required for your operation. Unexpected movement of the table during operations could damage the cutter or workpiece.**

## Table & Knee Locks

Refer to **Figures 22–23** for the locations of the locks used to secure the table in place.



**Figure 22. Locations of the X- and Y-axes table locks.**

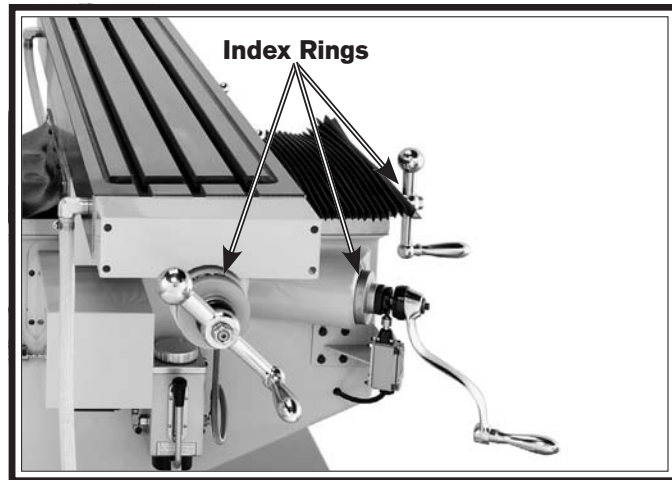


**Figure 23. Locations of the Z-axis (knee) locks.**

## Graduated Index Rings

The table ball handles and Z-axis crank have graduated index rings attached (see **Figure 24**) that display the amount table movement in the increments, as shown in the table below:

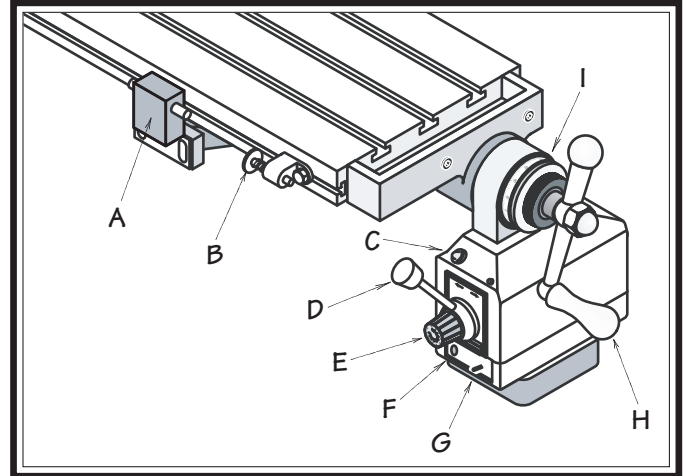
Axis	Individual Increment	One Full Revolution
X	0.001"	0.200"
Y	0.001"	0.200"
Z	0.001"	0.100"



**Figure 24. Graduated table index rings.**

## X-Axis Power Feed

The mill is equipped with a power feed unit for X-axis table movement. Refer to the illustration in **Figure 25** and the descriptions below to understand the functions of the various components of the power feed system.



**Figure 25. Power feed system components.**

- A. Limit Switch:** Stops table movement when either side plunger is pressed by a limit stop.
- B. Limit Stop:** Adjusts along the length of the table to restrict table movement.
- C. Rapid Traverse Button:** Moves the table at full speed when pressed.
- D. Directional Lever:** Controls direction of table movement. The middle position is neutral.
- E. Speed Dial:** Controls the speed of table movement. Turning the dial clockwise causes the table to move faster.
- F. Circuit Breaker Reset Button:** Resets the internal circuit breaker if the unit becomes overloaded and shuts down.
- G. Power Switch:** Turns the power feed **ON** and **OFF**.
- H. X-Axis Ball Handle:** Manually moves the table.
- I. Graduated Index Ring:** Displays the distance of table travel in 0.001" increments, with one full revolution equal to 0.200" of table travel.

## Operating X-Axis Power Feed

To confirm the power feed settings you will be using during operation, we recommend that you raise the cutter above the workpiece, then use the power feed to move the table through the intended cutting path before starting the spindle rotation and taking the cut.

### Tool Needed

### Qty

Hex Wrench 12mm ..... 1

### To operate the X-axis power feed:

1. Loosen the X-axis table locks (refer to **Figure 22** on **Page 29** for locations).
2. Position the limit stops along the front table slot to limit the distance of table travel that is correct for your operation.

**Note:** Make sure the cap screws firmly secure the limit stops in place when positioned.

3. Turn the speed dial all the way counterclockwise to the slowest setting, move the directional lever to neutral (middle) position, then flip the power switch up to turn the unit **ON**.
4. With your hand poised over the power switch in case you need to suddenly turn the unit **OFF**, move the directional lever in the desired direction of table travel.
5. Use the speed dial to slowly bring the speed of movement up to the desired rate.
6. When you are finished using the power feed, turn it **OFF**, then rotate the speed dial all the way counterclockwise and move the directional lever to the neutral (middle) position to avoid unexpected table movement when you next flip the power switch up.

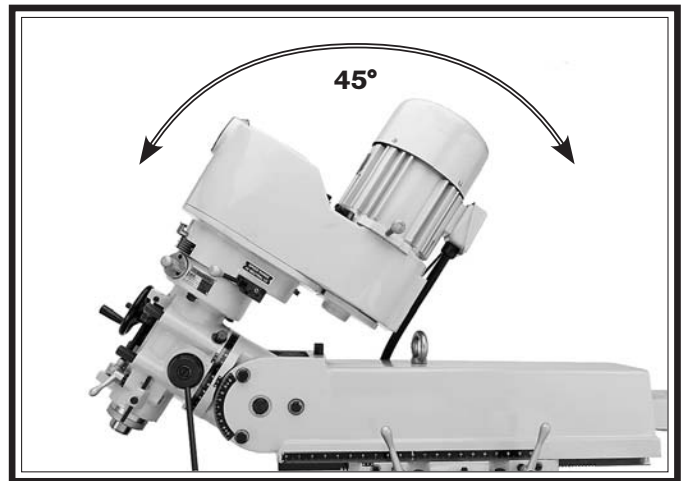
# Head Movement

The mill head tilts 45° up and down, and rotates 90° left and right, as shown in **Figures 26–27**.

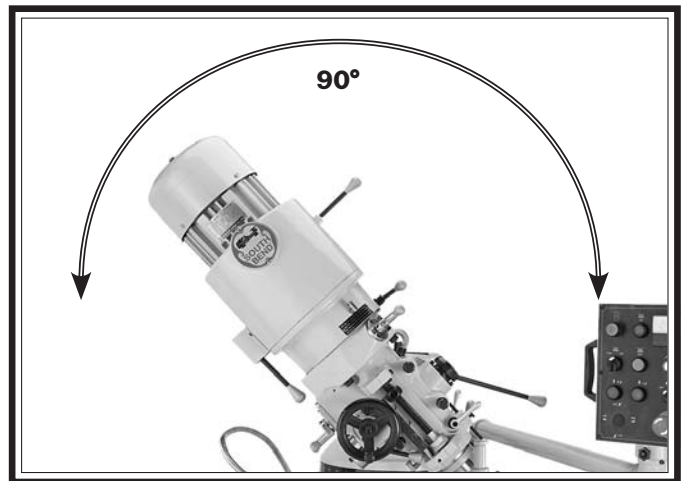
<b>Tool Needed</b>	<b>Qty</b>
Wrench 19mm .....	1

**NOTICE**

Always lock the head firmly in place after tilting or rotating it. Unexpected movement of the head during operations could cause damage to the cutter or workpiece.



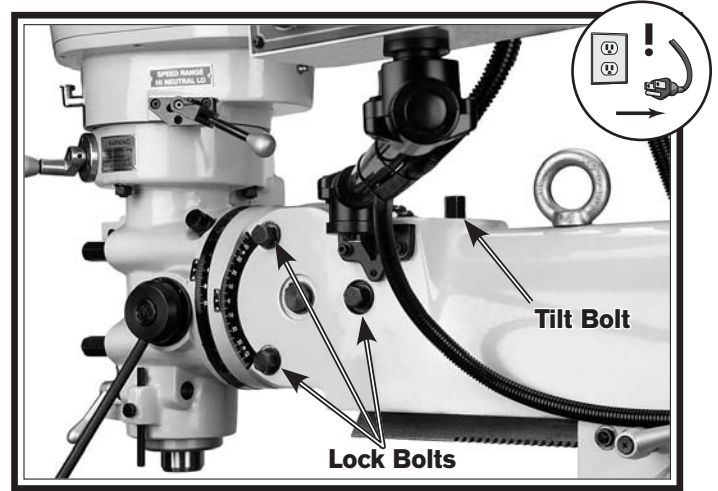
**Figure 26. Head tilts 45° back and forth.**



**Figure 27. Head tilts 90° left-and-right.**

# Tilting Head

1. DISCONNECT MILL FROM POWER!
2. Loosen the three tilt lock bolts on the right side of the ram adapter shown in **Figure 28**.

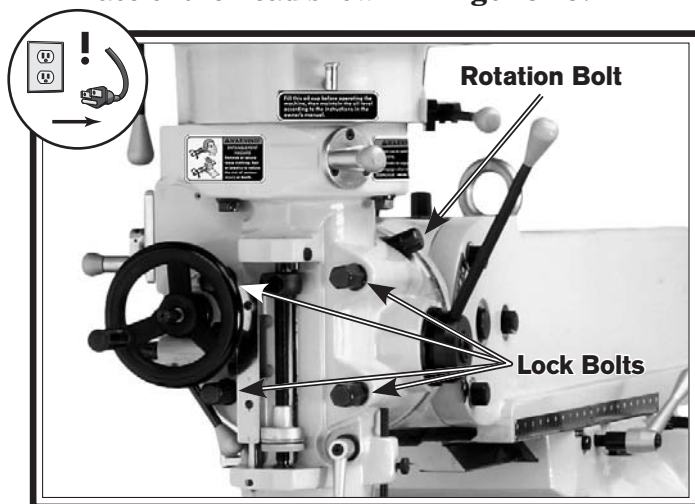


**Figure 28. Head tilting controls.**

3. Use one hand to apply pressure to the head in the direction of tilt, then slowly rotate the tilt bolt. Rotating this bolt clockwise will tilt the head back.
4. When the head is in the correct position for your operation, re-tighten all three lock bolts.

## Rotating Head

1. DISCONNECT MILL FROM POWER!
2. Loosen the four rotation lock bolts on the face of the head shown in **Figure 29**.



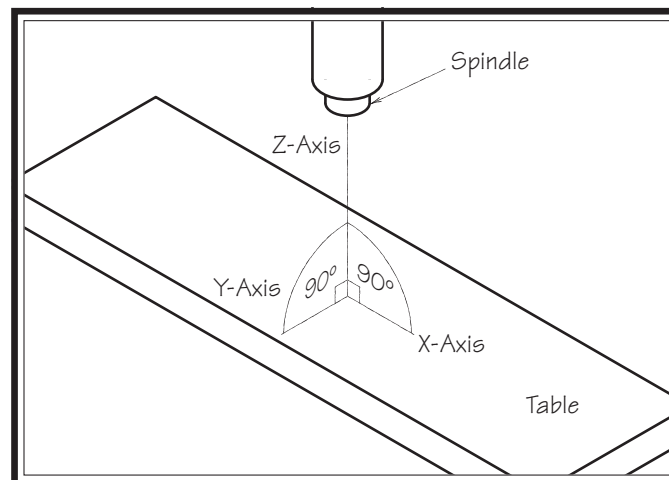
**Figure 29. Head rotating controls.**

3. Use one hand to apply pressure in the direction of rotation, then slowly turn the rotation bolt.
4. Re-tighten the lock bolts when you have the head in the desired position.

## Tramming Spindle

When your operation requires that the spindle axis be precisely perpendicular to the table, you must tram or align the spindle with the table to ensure the spindle is exactly 90° to the table.

This procedure involves mounting a dial test indicator to the quill or spindle, rotating it around the table, and adjusting the head position so that the spindle axis is 90° to the table X- and Y-axes, as illustrated in **Figure 30**.



**Figure 30. Spindle axis perpendicular to the table X- and Y-axes.**

We encourage you to research the many variations of spindle tramming to find the one that works best for you. If you do not already have a preference for performing this operation, use the following procedure.

**Note:** Keep in mind that the top surface of your workpiece will not likely be exactly parallel with the table top. Depending on your operation, you may choose to tram the spindle to the top surface of the workpiece after it is mounted instead of tramming the table.

**Tools Needed**

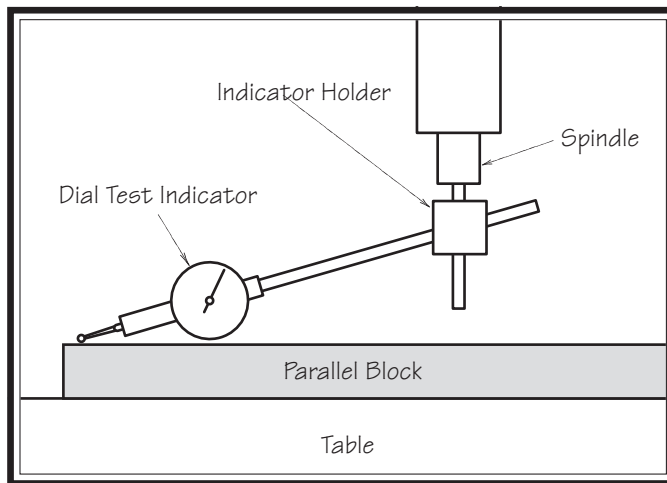
Dial Test Indicator	<b>Qty</b>
(with at least 0.0005" resolution) .....	1
Indicator Holder	
(mounted on the quill/spindle) .....	1
Precision Parallel Block.....	1

**Note:** A precision-ground plate can be substituted for the parallel block. Keep in mind that the farther the indicator point can be placed from the spindle axis, the more accurate the alignment measurements will be.

**To tram the spindle to the table:**

1. DISCONNECT MILL FROM POWER!
2. Prepare the mill by performing the following tasks:
  - Stone the table to remove all nicks and burrs, then clean off all debris. Verify the table is clean by running your hand over the top of it.
  - Position the table for the milling operation you intend to perform after the tramping—preferably centered to the saddle.
  - Tighten any table, knee, quill, or ram locks that should be tight during the intended milling operation.
3. Place the parallel block underneath the spindle.

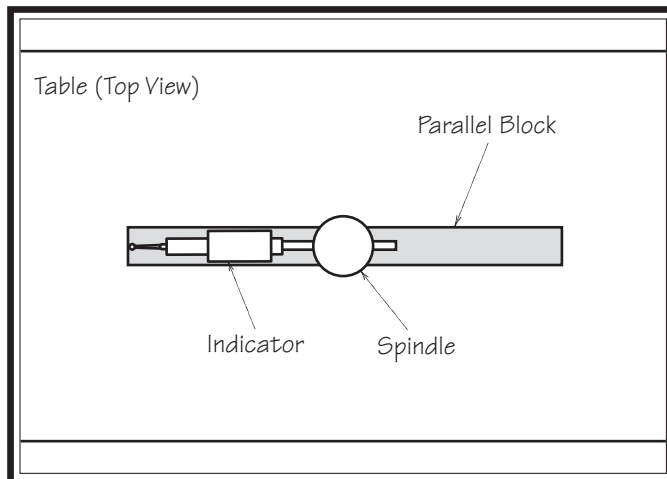
4. Install the indicator holder into the spindle or onto the quill, then mount the indicator onto it so that the point is as parallel to the block as possible (see the illustration in **Figure 31** for an example).



**Figure 31. Dial test indicator mounted.**

5. To measure spindle alignment along the X-axis, place the parallel block directly under the spindle and the indicator across the length of the table, as illustrated in **Figure 32**.

**Note:** If you must re-position the quill or the knee to accommodate the above step, then review the tasks in **Step 2** to make sure the mill is properly prepared for tramping.



**Figure 32. Parallel block positioned for the X-axis measurement (top view).**

**Note:** Generally, the goal in the next steps is to get the difference of the indicator readings between the ends of the parallel bar down to 0.0005". However, the acceptable variance will depend on the requirements for your operation.

6. Rotate the spindle by hand so that the indicator point rests on one end of the parallel block, as illustrated in **Figure 32**, then zero the dial.
7. Rotate the spindle so that the indicator point rests in the same manner on the other end of the block, then read the dial.

— If the indicator dial still reads zero or is within the acceptable variance, continue on with **Step 8**.

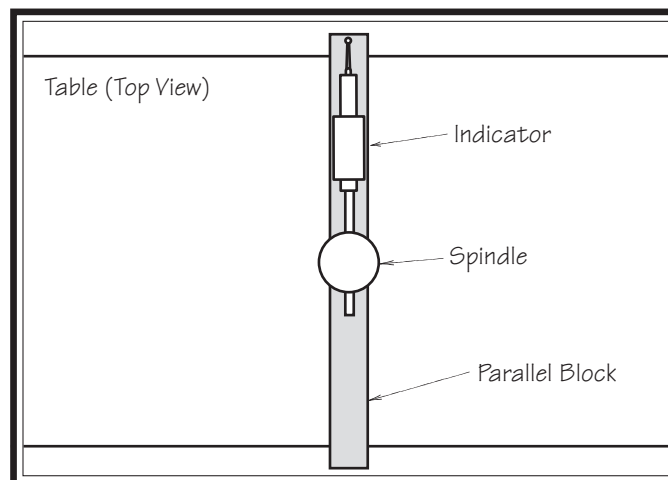
— If the indicator dial has moved from zero beyond the acceptable variance, you will need to compensate for that amount by rotating the head left or right. Repeat **Steps 6–7** until you are satisfied with the spindle axis alignment along the table X-axis.

**Tip:** Keep one of the rotation lock bolts snug so that the head does not move loosely while you adjust it small amounts.

8. Re-tighten the rotation lock bolts.

**Note:** It is a good idea to repeat **Steps 6-7** again in case the head moved slightly during the process of re-tightening the lock bolts.

9. Place the parallel block directly under the spindle and across the width of the table, as illustrated in **Figure 33**.



**Figure 33. Parallel block positioned for the Y-axis measurement (top view).**

10. Rotate the spindle so that the indicator point rests on the parallel bar, as illustrated in **Figure 33**, then zero the dial.
11. Rotate the spindle so that the indicator point rests on the other end of the bar in the same manner, then read the dial.

— If the indicator dial still reads zero or is within the acceptable variance, the spindle is precisely perpendicular to the table in both the X- and Y-axes and the tramping procedure is complete.

— If the indicator dial has moved from zero beyond the acceptable variance, you will need to compensate for that amount by tilting the head forward or backward. Repeat **Steps 9–10** until you are satisfied with the spindle axis alignment along the table Y-axis.

**Tip:** Keep one of the tilt lock bolts snug so that the head is not completely loose while you adjust it in small amounts.

12. Re-tighten the tilt lock bolts.

**Note:** It is a good idea to repeat **Steps 10–11** again in case the head moved slightly during the process of re-tightening the lock bolts.

## Ram Movement

The ram travels forward and backward 19½" and rotates horizontally 360° in either direction around the turret.

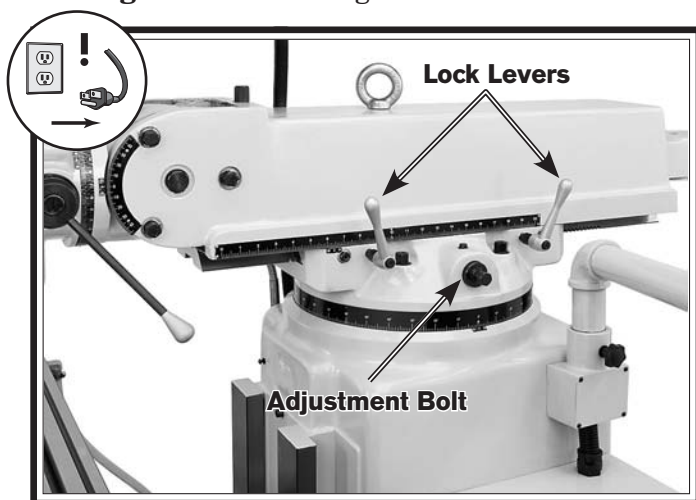
### Tool Needed

Wrench 19mm ..... 1

Qty

### Moving Ram Back and Forth

1. DISCONNECT MILL FROM POWER!
2. Loosen the two lock levers shown in **Figure 34** on the right side of the ram.



**Figure 34. Ram forward and backward movement controls.**

3. Make sure there are no obstructions to ram travel, especially with the spindle tool around the workpiece, then slowly rotate the adjustment bolt to move the ram. Rotating the bolt clockwise will move the ram backward.
4. Re-tighten the lock levers after you have re-positioned the ram.

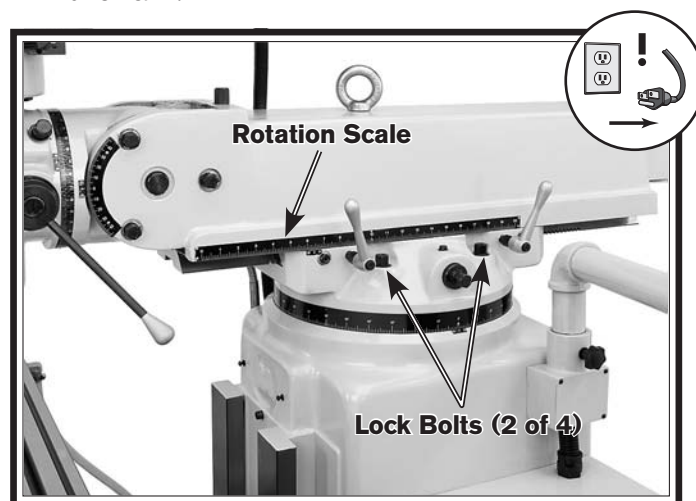
## NOTICE

**Always lock the ram firmly in place after moving it. Unexpected movement of the ram and head during operations could cause damage to the cutter or workpiece.**

### Rotating Ram

1. DISCONNECT MILL FROM POWER!
2. Loosen the four lock bolts on top of the turret (see **Figure 35**).

**Note:** There are two lock bolts on either side of the ram.



**Figure 35. Ram rotating controls.**

- Note:** In the next step, take care not to entangle or stretch the electrical cabling as you move the ram around the turret.
3. Push on the head to manually rotate it. Use the rotation scale to determine the correct position for your operation, then re-tighten the four lock bolts to secure the ram in place.

## Setting Spindle Speed

Using the correct spindle speed is important for safe and satisfactory results, as well as maximizing tool life.

To set the spindle speed for your operation, you will need to: (1) Determine the best spindle speed for the cutting task, and (2) configure the mill controls to produce the required spindle speed.

### Determining Spindle Speed

Many variables affect the optimum spindle speed to use for any given operation, but the two most important are the recommended cutting speed for the workpiece material and the diameter of the cutting tool, as noted in **Figure 36**:

<p>*Recommended Cutting Speed (FPM) x 12</p> <hr/> <p>Tool Dia. (in inches) x 3.14</p> <p>= Spindle Speed (RPM)</p> <p>*Double if using carbide cutting tool</p>
--

**Figure 36. Spindle speed formula for milling.**

Cutting speed, typically defined in feet per minute (FPM), is the speed at which the edge of a tool moves across the material surface.

A recommended cutting speed is an ideal speed for cutting a type of material in order to produce the desired finish and optimize tool life.

The books **Machinery's Handbook** or **Machine Shop Practice**, and some internet sites, provide excellent recommendations for which cutting speeds to use when calculating the spindle speed. These sources also provide a wealth of additional information about the variables that affect cutting speed and they are a good educational resource.

Also, there are a large number of easy-to-use spindle speed calculators that can be found on the internet. These sources will help you take into account all applicable variables to determine the best spindle speed for the operation.

## NOTICE

**To avoid damage to the spindle, gears, or cutting tools:**

- **Spindle rotation must be turned OFF and the spindle must be completely stopped BEFORE you change the spindle speed range.**
- **The mill is designed to ONLY operate with the spindle speed range selector in either the high or low position. To avoid damaging the moving parts inside the headstock, never start spindle rotation without the range selector detent pin firmly seated in either the high or low position.**
- **When changing the spindle speed range, the direction of spindle rotation will reverse due to the change in gear configuration. You will need to use the spindle direction switch to change the rotation back to the original direction.**

### Setting Spindle Speed Range

Setting the spindle speed range involves using the spindle speed range lever to engage/disengage the spindle spline with the bull gear.

**To set the spindle speed range:**

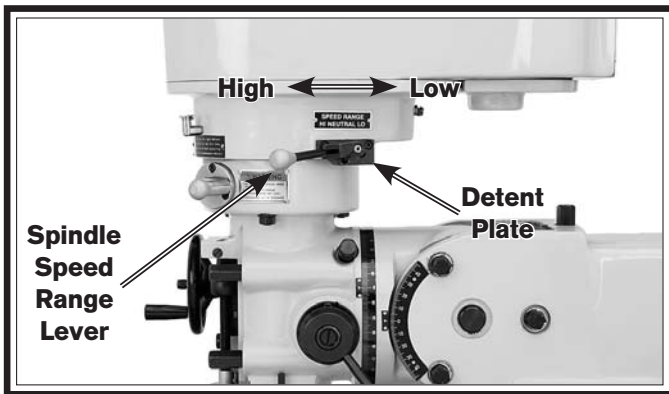
1. DISCONNECT MILL FROM POWER!
2. Use the chart below to find the spindle speed range that includes the required spindle speed for your operation.

Spindle Speed Ranges	
Low Range	60–575 RPM
High Range	575–5000 RPM

3. Press the spindle speed range lever (shown in **Figure 37**) toward the head to release the pin from the detent plate, then move selector so that the pin is over the other detent and release it.

— When the lever points to the rear and the front detent is engaged, the low speed range is selected. Conversely, when the lever points toward the front and the rear detent is engaged, the high speed range is selected.

**Note:** It may be necessary to turn the spindle by hand as you move the range lever to allow the gears to mesh.

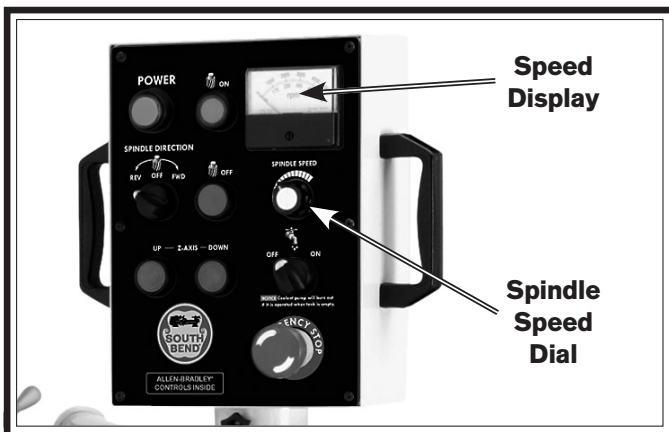


**Figure 37. Spindle speed range selector.**

### Setting Spindle Speed

Use the spindle speed dial and display (see **Figure 38**) to set the required spindle speed within the speed range selected.

The top values of the spindle speed display are for the high spindle speed range, and the bottom values are for the low range.



**Figure 38. Spindle speed dial and display.**

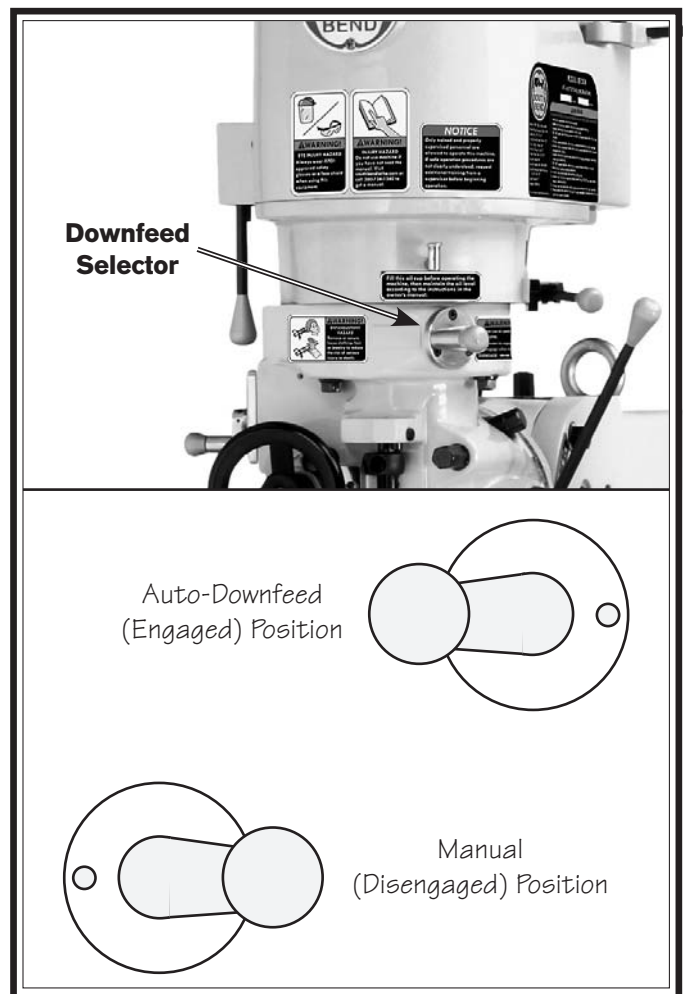
## Downfeed Controls

Spindle downfeed movement is controlled by three mechanisms: 1) The coarse downfeed handle, 2) the fine downfeed handwheel, and 3) the auto-downfeed system.

### Coarse Downfeed

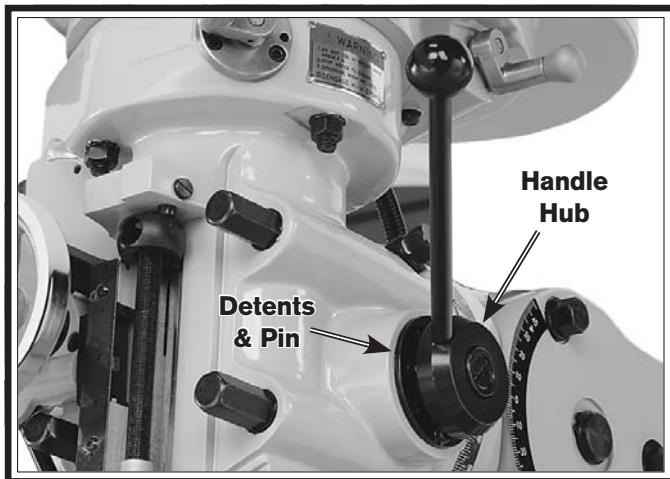
1. DISCONNECT MILL FROM POWER!
2. To set the downfeed for manual control, pull the downfeed selector knob out (see **Figure 39**), then rotate it clockwise until the selector pin under the knob seats in the forward manual (disengaged) position.

**Note:** It may be necessary to turn the spindle by hand as you move the selector to allow the gears to mesh.



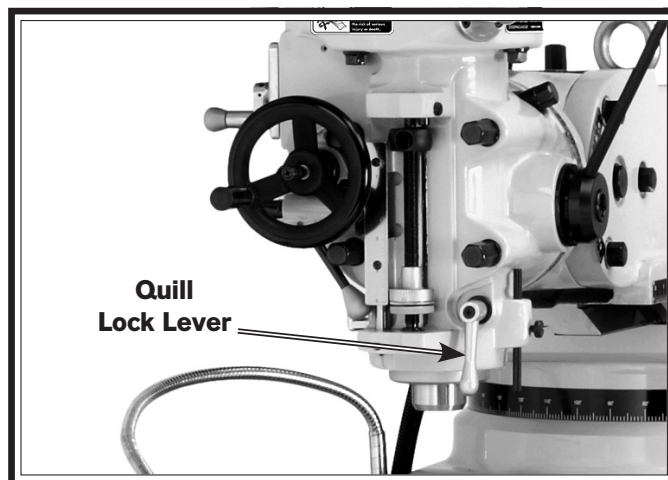
**Figure 39. Downfeed selector.**

3. Make sure the selector pin is firmly seated in the detent by attempting to move the selector without pulling the knob out.
4. Make sure the pin of the coarse downfeed handle hub is engaged with one of the detents on the downfeed sleeve (see **Figure 40**).



**Figure 40. Coarse downfeed handle hub, detents, and pin.**

5. Make sure the quill lock lever is loose so that the quill can move easily (see **Figure 41**).

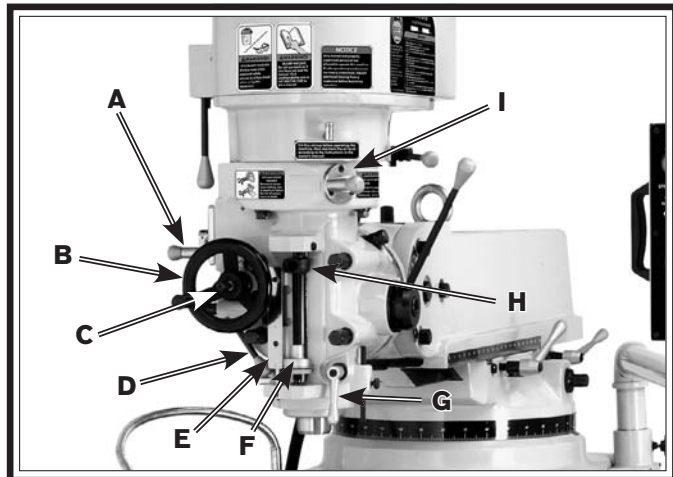


**Figure 41. Location of the quill lock lever.**

6. Rotate the coarse downfeed handle around the hub to control the depth of the spindle.

## Fine Downfeed Controls

There are a number of controls on the head that are used with the fine downfeed handwheel or the auto-downfeed system. Refer to **Figure 42** and the descriptions that follow to become familiar with these controls.



**Figure 42. Fine downfeed controls.**

**A. Auto-Downfeed Rate Selector:** Selects one of the three auto-downfeed rates.

**B. Fine Downfeed Handwheel:** Manually controls fine spindle downfeed.

**NOTICE**

**When the spindle rotation is reversed, either by changing the spindle speed range or by using the spindle direction switch, the direction of spindle auto-downfeed will reverse.**

**C. Auto-Downfeed Direction Pin:** Starts, stops, and reverses the auto-downfeed direction.

**D. Fine Downfeed Clutch Lever:** Engages the fine/auto-downfeed gears.

**E. Downfeed Scale:** Used with the quill dog, shows the depth of spindle downfeed in inches.

**F. Downfeed Stop & Locking Wheel:** Sets the depth of spindle downfeed. The stop is threaded into position, then the locking wheel is used to secure it in place.

**G. Quill Lock Lever:** Secures the quill in place for increased stability during operations.

**H. Quill Dog:** Moves with the quill and spindle, and disengages the downfeed clutch lever when it meets either the top or downfeed stop.

**I. Downfeed Selector:** Sets the mill for manual downfeed or auto-downfeed control.

## Fine Downfeed Handwheel

1. Make sure that the spindle rotation is turned **OFF** and the spindle is at a complete stop.

2. Pull the downfeed selector knob out, then rotate the selector clockwise until the selector pin seats in the forward manual (disengaged) position. This will set the downfeed for manual control.

3. Set the auto-downfeed direction pin in the neutral (middle) position to disengage the fine downfeed handwheel from the auto-downfeed gears.

4. Position the downfeed stop at the spindle depth that is correct for your operation, then secure it in place with the locking wheel.

5. Use the coarse downfeed lever to slightly lower the spindle until you can pull the clutch lever out to the left and it locks in place. This will engage the fine downfeed handwheel with the quill and spindle.

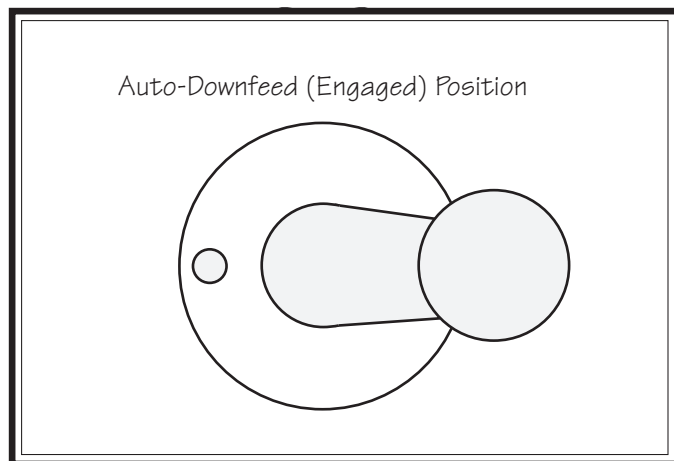
6. To lower the spindle, rotate the fine downfeed handwheel. When the quill dog meets the downfeed stop, the clutch lever will disengage and the spindle will return to the top.

## Auto-Downfeed System

When using the auto-downfeed system, the spindle will move in the direction you choose with the auto-downfeed direction pin. When the quill dog reaches the top or meets the downfeed stop, the downfeed clutch lever releases. Then, if the spindle was traveling upward, the movement simply stops. If the spindle was traveling downward, then the spindle moves back to the top at a rate controlled by the return spring on the left side of the head.

### To use the auto-downfeed system:

1. Make sure that the spindle rotation is turned **OFF** and the spindle is at a complete stop.
2. To set the mill for auto-downfeed, pull the downfeed selector knob out, then rotate the selector clockwise and seat the pin in the rear auto-downfeed (engaged) position, as illustrated in **Figure 43**.



**Figure 43. Downfeed selector in the auto-downfeed (engaged) position.**

3. Position the downfeed stop at the spindle depth that is correct for your operation, then secure it in place with the locking wheel.

4. Position the auto-downfeed direction pin for the spindle travel that is necessary for your operation. You may have to rock the fine downfeed handwheel back-and-forth to move the pin all the way in or out.

**Note:** The direction pin has three positions: 1) **In** for one downfeed direction, 2) **middle** for neutral or no movement, and 3) **out** for the reverse direction. The direction of spindle travel for the in and out positions is relative to the direction of spindle rotation. Keep in mind that spindle rotation and downfeed direction will reverse when the spindle speed range is changed and you will need to use the spindle direction switch to change the rotation direction back to the original.

5. Make sure the clutch lever is all the way to the right in the disengaged position so that the spindle will not travel when rotation is started.

**Note:** We recommend that you complete the remaining steps without a cutting tool installed, without a workpiece in place, and the table lower than the maximum spindle downfeed travel. This will enable you to test and confirm the settings before beginning the actual cutting operation.

## NOTICE

**To avoid damage to the system gearing, never use the auto-downfeed system with spindle speeds over 3000 RPM.**

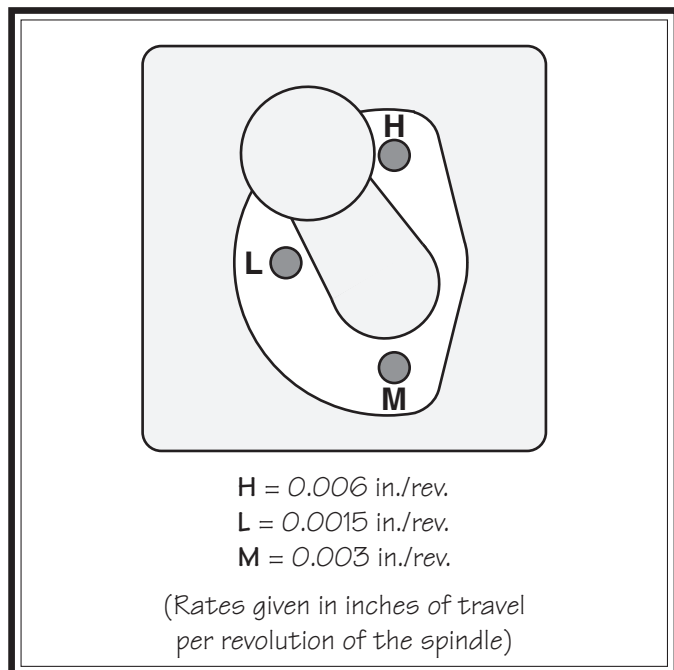
6. Set the correct spindle speed, then begin spindle rotation.

## NOTICE

To avoid the risk of gear damage, always start spindle rotation before using the auto-downfeed rate selector.

- Select one of the three downfeed rates by pulling the auto-downfeed rate selector knob out, position the selector over the appropriate detent, then release the knob. Make sure the pin is firmly seated by trying to move the selector without pulling the knob out.

**Note:** Refer to the illustration in **Figure 44** when selecting the downfeed rate.

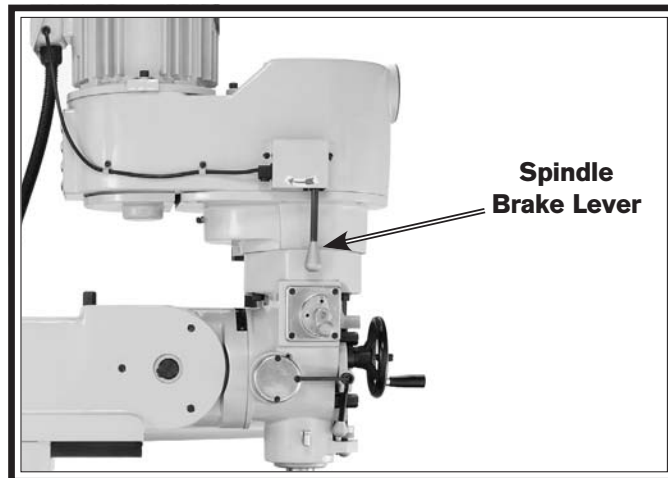


**Figure 44. Positions of the auto-downfeed rate selector.**

- Use the coarse downfeed lever to lower the spindle slightly until you can pull the clutch lever out to the left and it locks in place, which will start the auto-downfeed spindle travel.

## Spindle Brake

When pressed backward, the spindle brake lever (see **Figure 45**) activates a switch that turns the spindle motor **OFF** and engages drum-type brake pads to stop spindle rotation.



**Figure 45. Location of the spindle brake lever.**

## NOTICE

The spindle brake is typically used in an emergency situation where you need to stop the spindle in a hurry. Overuse of the spindle brake will lead to excessive wear of the brake pads and drum.

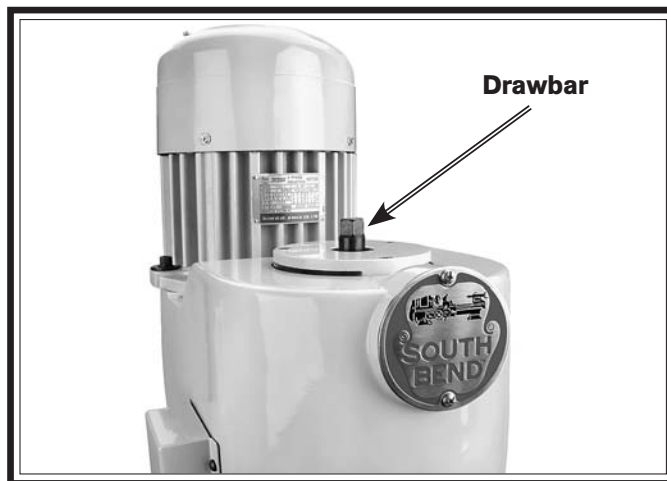
# Loading/Unloading Tooling

The mill is equipped with an R8 spindle taper and a 1/2"-20 x 18 1/2" spindle drawbar, as shown in **Figure 46**.



**Figure 46. Spindle drawbar and spacer.**

4. Align the tool keyway with the protruding pin inside the spindle taper, then firmly push the tool into the spindle to seat it.
5. With one hand holding the tool in place, insert the drawbar into the spindle from the top of the head, then thread it into the tool (see **Figure 47**).



**Figure 47. Drawbar loaded into the spindle.**

**⚠ CAUTION**

The sharp edges of tools can easily cut your hands and fingers. Always use protection when handling cutting tools.

6. Tighten the drawbar until it is snug. Avoid overtightening, as it could make removing the tool difficult.

## Loading Tooling

Tool Needed	Qty
Wrench 21mm .....	1

### To load tooling:

1. DISCONNECT MILL FROM POWER!
2. Clean any debris or surface substances from inside the spindle taper and the mating surface of the tooling.

**Note:** Debris or oily substances can prevent the tooling and spindle from properly mating. This condition can cause excessive vibration, poor cutting results, or tool/workpiece damage.

3. Place the mill in the low spindle speed range to keep the spindle from turning during the next steps.

## Unloading Tooling

Tools Needed	Qty
Wrench 21mm .....	1
Brass Hammer .....	1

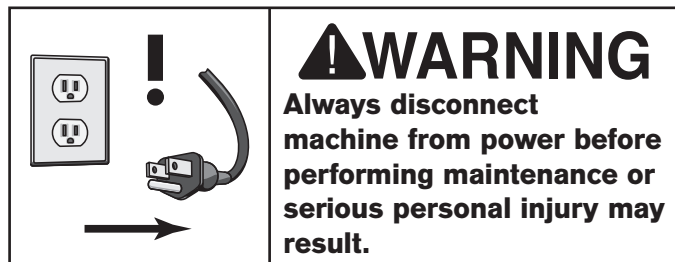
### To unload tooling:

1. DISCONNECT MILL FROM POWER!
2. Place the mill in the low spindle speed range to keep the spindle from turning during the next step.

**Note:** Make sure that the drawbar has at least three threads engaged with the tooling in the next step to avoid damaging the threads of the drawbar or tool.

3. Loosen the drawbar a couple of turns, then tap the top of it with brass hammer to knock the tool loose at the bottom of the spindle.
4. Support the tool with one hand, then completely unthread the drawbar.

## Maintenance Schedule



Regular maintenance will ensure proper care of the equipment. We strongly recommend that all operators make a habit of following the daily maintenance procedures.

For optimum performance from this machine, this maintenance schedule must be strictly followed. Use the **Monthly Maintenance Chart** on **Page 45** to ensure this is done.

### Ongoing

To maintain a low risk of injury and proper machine operation, if you ever observe any of the items below, shut the machine down immediately, disconnect it from power, and fix the problem before continuing operations.

- Loose mounting bolts or fasteners.
- Worn, frayed, cracked, or damaged wires.
- Emergency STOP button not working correctly.
- Missing belt guards.
- Reduction in braking speed or efficiency.
- Coolant not flowing correctly.
- Any other unsafe condition.

### Before Beginning Operations

- Make sure the electric box door is closed and properly latched.
- Turn the spindle direction switch to the STOP (middle) position and the speed dial all the way counterclockwise to prevent high-speed spindle startup when connected to power (see **Page 28**).
- Move the downfeed selector to the manual (disengaged) position to prevent the spindle from unexpectedly downfeeding when rotation is started (see **Page 38**).
- Make sure the X-axis power feed is turned **OFF** to prevent unintentional table movement when connected to power (see **Page 30**).
- Check the coolant reservoir in the base. Fill it or clean it out if necessary (see **Page 51**).
- Perform the lubrication tasks as directed in the **Lubrication** section on **Page 46**.
- Check table movement in all three axes for loose/tight gibs. Adjust the gibs if necessary (see **Page 54**).

### Daily, After Operations

- Push the emergency STOP button, turn the main power switch to the OFF position, and disconnect the machine from power.
- Vacuum/clean all chips and swarf from table, slides, and base.
- Wipe down all unpainted or machined surfaces with a high quality rust preventative.

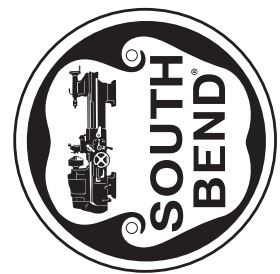
**South Bend Lathe Co.® Monthly Maintenance Chart for Model SB1027 Milling Machine**

Item	Day	1	2	3	4	5	6	7	8	9	10	11	12	13	14	15	16	17	18	19	20	21	22	23	24	25	26	27	28	29	30	31										
<b>Inspection</b>																																										
Coolant System																																										
Gib Adjustment																																										
<b>End of Day</b>																																										
Disconnected From Power																																										
Cleaned & Protected																																										
<b>Lubrication</b>																																										
Quill																																										
Table & Lead-screws																																										
Speed Range Bearing Sleeve																																										
Headstock Gearing																																										
Z-axis Leadscrew																																										
Power Feed Gears																																										

Use this chart to keep track of the maintenance performed on the mill. Cross out or initial the "Day" box for each item on the list. If the box is blacked out, maintenance is not required for that item on that day.

Make copies of this page to use each month. Keep each chart as a maintenance record for the mill.

**Month/Year:**



(360) 734-1540 • FAX: (360) 676-1075  
www.southbendlathe.com

## Cleaning

Regular cleaning is one of the most important steps in taking good care of this machine. In most shops, each operator is responsible for cleaning the machine immediately after using it or at the end of the day. We recommend that the cleaning routine be planned into the workflow schedule, so that adequate time is set aside to do the job right.

Typically, the easiest way to clean swarf from the ways and table is to use a wet/dry shop vacuum that is dedicated for this purpose only. The small chips leftover after vacuuming can be wiped up with a slightly oiled rag. Avoid using compressed air to blow off chips, as it may drive them deeper into moving surfaces and could cause sharp chips to fly into your face or hands.

All visible swarf should be removed from the mill during cleaning.

## Unpainted & Machined Surfaces

Besides the ways, all other unpainted and machined surfaces should be wiped down daily to keep them rust-free and in top condition. This includes any surface that is vulnerable to rust if left unprotected (especially any parts that are exposed to water soluble cutting fluids). Typically, a thin film of oil is all that is necessary for protection.

## Lubrication

The mill has numerous moving metal-to-metal contacts that require regular and proper lubrication to ensure efficient and long-lasting operation, and to protect your investment.

Other than the lubrication points covered in this section, all other bearings are internally lubricated and sealed at the factory. Simply leave them alone unless they need to be replaced.

Before performing any lubrication task, **DISCONNECT THE MILL FROM POWER!**

**Important:** Before adding lubricant, clean the debris and grime from the oil cup or grease fitting and the immediate area to prevent contamination of the oil cups, grease fittings, or new lubricant.

Use the schedule and information in **Figure 48** as a daily guide for lubrication tasks.

### **NOTICE**

**The following recommended lubrication schedule is based on light-to-medium usage. Keeping in mind that lubrication helps to protect the value and operation of the mill, these lubrication tasks may need to be performed more frequently depending on usage.**

Lubrication Task	Frequency (Hours of Operation)	Page Ref.
Quill	3–4 hrs.	47
Table Ways & Leadscrews (One-Shot Oiler)	4–8 hrs.	47
Speed Range Bearing Sleeve	Before Every Use	48
Headstock Gearing	40 hrs.	48
Ram Ways	40 hrs.	48
Power Feed Gears	160 hrs.	49

**Figure 48. Recommended lubrication tasks, schedules, and instruction page references.**

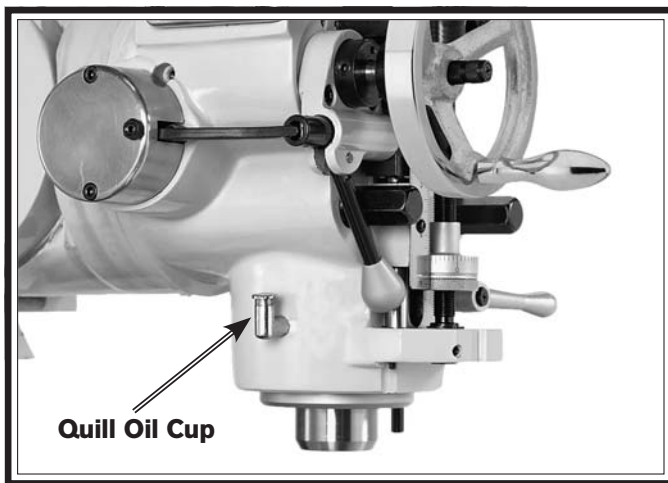
**NOTICE**

**Failure to follow reasonable lubrication practices as instructed in this manual could lead to premature failure of mill components and will void the warranty.**

**Quill**

Oil Type ..... Mobil Vactra 2 or ISO 68 Equivalent  
 Oil Amount ..... Fill Oil Cup  
 Check/Add Frequency ..... 4 hrs. of Operation

Lift the oil cup cap shown in **Figure 49** to fill it with lubricant.



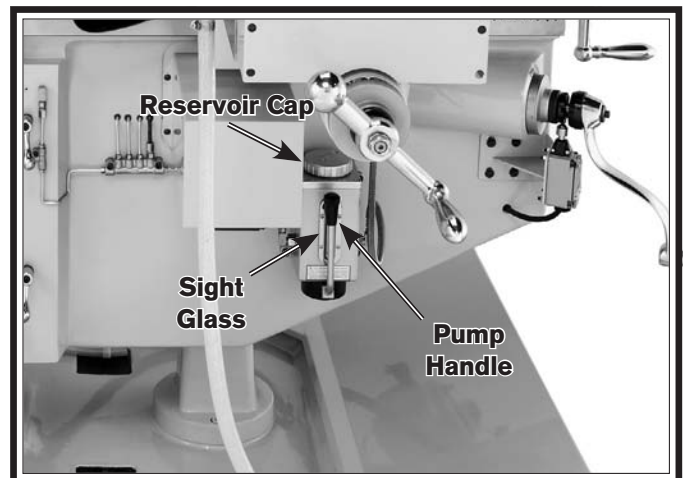
**Figure 49. Quill oil cup location.**

**Table Ways (One-Shot Oiler)**

Oil Type ..... Mobil Vactra 2 or ISO 68 Equivalent  
 Oil Amount ..... One Pull of Pump Handle  
 Check/Add Frequency ..... 4–8 hrs. of Operation  
 Reservoir Capacity ..... Approx. 1¼ Pints

The one-shot oiler is connected to a series of aluminum tubes that carry the lubricant to wear points along the table, saddle, knee ways, and the leadscrews. After using the oiler pump handle shown in **Figure 50**, move the table through all paths of movement to evenly distribute the lubricant.

Use the sight glass on the side of the oiler to know when to re-fill the reservoir.



**Figure 50. One-shot oiler controls.**

### Speed Range Bearing Sleeve

Oil Type ..... Mobil Vactra 2 or ISO 68 Equivalent  
Oil Amount ..... Fill Oil Cup  
Check/Add Frequency ..... Before Every Use

Lift the oil cup cap shown in **Figure 51** to fill it with lubricant.



**Figure 51. Speed range bearing sleeve.**

### Headstock Gearing

Grease Type.....NLGI 2 or Equivalent  
Grease Amount ..Two Pumps From a Grease Gun  
Check/Add Frequency .....40 hrs. of Operation

Add two pumps from a grease gun to the grease fitting shown in **Figure 52**.



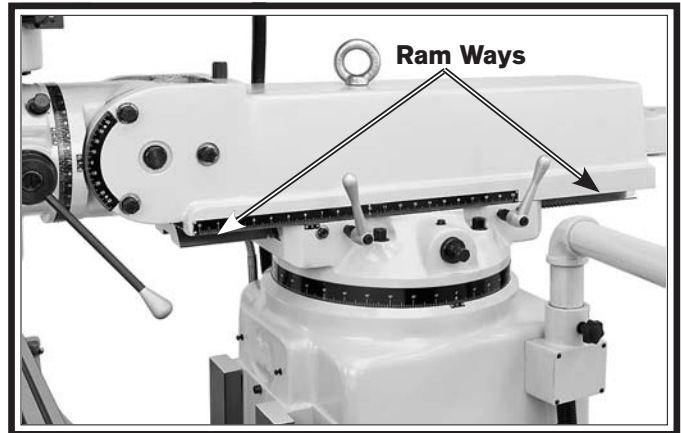
**Figure 52. Headstock gearing grease fitting.**

### Ram Ways

Oil Type ..... Mobil Vactra 2 or ISO 68 Equivalent  
Oil Amount ..... Thin Coat  
Check/Add Frequency .....40 hrs. of Operation

Move the ram back and forth as necessary to access the full length of the ways (see **Figure 53**), then use a clean shop rag to apply a thin coat of lubricant.

**Note:** Do not get any oil on the ram rack (refer to the next subsection).

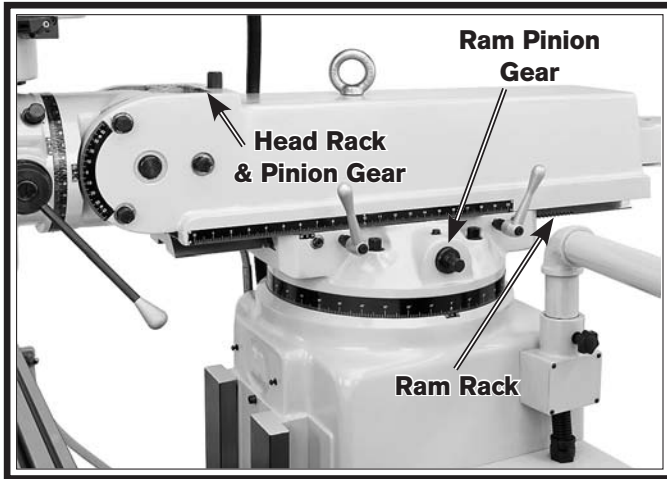


**Figure 53. Exposing the ram ways for lubrication.**

### Head & Ram Rack & Pinion Gear

The interaction between the cast iron surfaces of these devices (see **Figure 54**) produces a dry powder that provides an adequate lubrication.

Do not apply any other lubricant which could produce a stiff compound that may interfere with smooth movement.



**Figure 54. Locations of head and ram rack and pinion gears.**

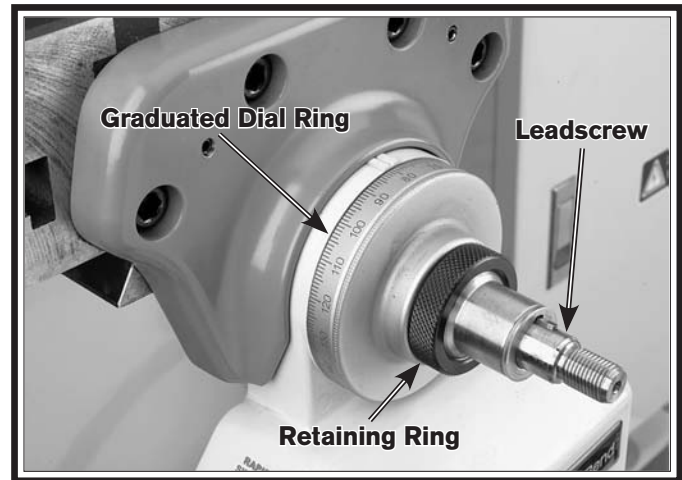
### Power Feed Gears

Grease Type.....Medium-Weight Lithium Grease  
 Grease Amount ..Two Pumps From a Grease Gun  
 Check/Add Frequency .....40 hrs. of Operation

<b>Tool Needed</b>	<b>Qty</b>
Wrench 19mm .....	1

#### To lubricate the power feed gears:

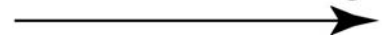
1. DISCONNECT MACHINE FROM POWER!
2. Remove the hex nut and ball handle from the power unit end of the X-axis leadscrew (see **Figure 55**).



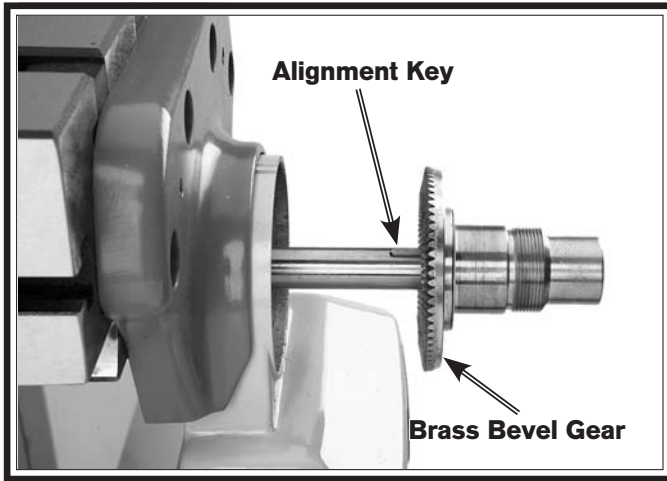
**Figure 55. Power feed ball handle removed.**

3. Unthread and remove the knurled retaining ring and graduated dial ring from the end of the leadscrew.

**Continued On Next Page**

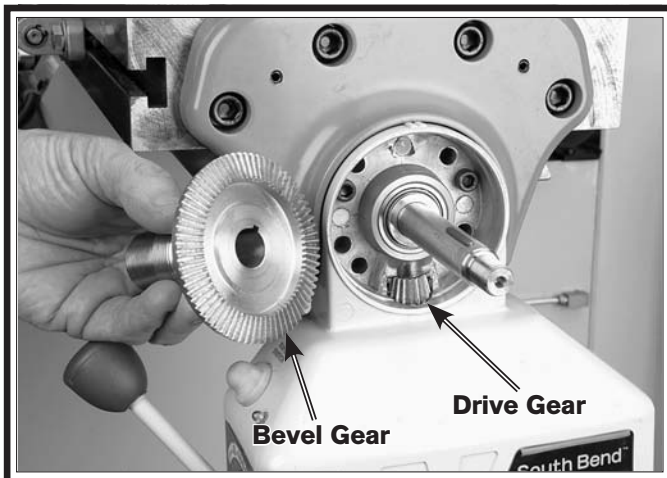


4. Remove the brass bevel gear from the leadscrew, then remove the leadscrew alignment key (see **Figure 56**).



**Figure 56. Power feed brass gear and leadscrew alignment key.**

5. Brush a light coat of lubricant on the bevel gear teeth and the smaller drive gear (see **Figure 57**).



**Figure 57. Power feed brass gear and drive gear.**

6. Replace the leadscrew alignment key, then align the bevel gear keyway with the key as you slide the gear onto the leadscrew and mesh its teeth with the drive gear.



7. Replace the graduated dial ring into position and secure it with the knurled retaining ring—do not overtighten.
8. Slide the ball handle onto the leadscrew, align the keyway with the leadscrew alignment key, then secure it with the hex nut removed in **Step 2**.
9. Move the table with the power feed ball handle to check the gear movement and distribute the grease on the gears. If the movement is not smooth, repeat **Steps 2–8** until it is.

# Coolant Reservoir

## Hazards

As some cutting fluid ages, dangerous microbes can proliferate and create a biological hazard. The risk of exposure to this hazard can be greatly reduced by replacing the old cutting fluid on a monthly basis, as indicated in the maintenance schedule.

The important thing to keep in mind when working with the cutting fluid is to minimize exposure to your skin, eyes, and respiratory system by wearing the proper PPE (personal protective equipment), such as splash-resistant safety glasses, long-sleeve gloves, protective clothing, and a NIOSH approved respirator.

	<p><b>! WARNING</b>  <b>BIOLOGICAL &amp; POISON HAZARD!</b></p> <p>Use the correct personal protection equipment when handling cutting fluid. Follow federal, state, and fluid manufacturer requirements for proper disposal.</p>
	

A small amount of coolant is lost during normal operation. Check the coolant reservoir regularly and fill it if necessary. We recommend changing the coolant every three months or sooner if it develops an unpleasant odor. However, be sure to follow the coolant manufacturer's instructions when checking, adding, or changing coolant.

The coolant reservoir holds approximately five gallons (19 liters) of fluid.

## Checking Coolant Level

Tools Needed	Qty
Hex Wrench 3mm .....	1
Piece of Wire.....	1

### To check the coolant level:

1. DISCONNECT MILL FROM POWER!
2. Clean away debris and grime from the coolant drain screens on the base of the mill (see **Figure 58**), then insert a clean and dry piece of wire through one of the screens to check the level of the coolant.

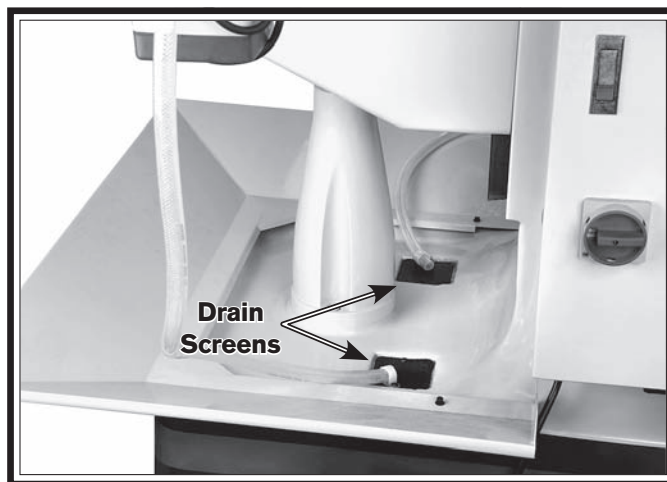


Figure 58. Locations of the coolant drain screens.

<h2><b>NOTICE</b></h2> <p>Running the coolant pump without adequate coolant in the reservoir may permanently damage the coolant pump. This action is considered abusive and is not covered by the warranty.</p>
---

3. If the level of coolant in the reservoir is less than 2", add more fluid through the screen to fill the tank.

## Changing Coolant

### Tools Needed

	Qty
Hex Wrench 3mm .....	1
Hex Wrench 5mm .....	1
Catch Pan .....	1
Bucket 5 Gal. ....	1
Rubber Hose (optional) .....	1

### To change the coolant:

1. Put on personal protective equipment.
2. Place a the catch pan on the table, position the coolant nozzle over the pan, then use the coolant pump to drain the reservoir.

**Note:** When the catch pan is near full, empty it into the 5 gallon bucket, then repeat the process.

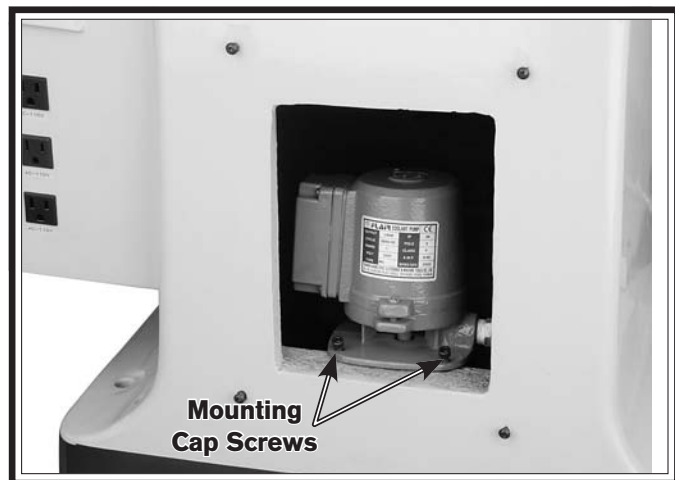
**Tip:** Alternately, slide a rubber hose onto the coolant nozzle and point it into the 5 gallon bucket.

3. DISCONNECT MILL FROM POWER!
4. Remove the coolant reservoir access panel from the rear of the column.
5. Remove the two pump mounting cap screws and move the pump out of the way (see **Figure 59**).

6. Thoroughly clean out the bottom of the reservoir and the base of the pump. Make sure that the interior is completely dry before adding new coolant.

**Note:** Use a cleaning solution that is compatible with the type of coolant. For instance, if you are using a water-base coolant, then use a water-base cleaning solvent.

7. When the reservoir and pump are clean and dry, replace the pump, access panel, and drain plug.
8. Clean away debris and grime from the coolant drain screens on the base of the mill (see **Figure 58** on the previous page), then pour the coolant through one of the screens to fill the reservoir.



**Figure 59. Location of coolant pump.**

## Machine Storage

To avoid rust problems or corrosion damage, properly prepare the mill for storage if it will not be operated for any length of time.

### To prepare the mill for storage:

1. DISCONNECT MILL FROM POWER!
2. Lubricate the mill as directed in the **Lubrication** section beginning on **Page 46**.
3. Clean out the coolant reservoir in the base of the mill as directed in the **Changing Coolant** section on **Page 52**.
4. Thoroughly clean all unpainted, bare metal surfaces, then coat them with quality rust preventative. Take care to ensure these surfaces are completely covered but that the rust preventative is kept off painted surfaces.
5. Loosen the belts to prevent them from stretching during storage. Post a reminder on the mill that the belts need to be re-installed or tensioned before resuming operations.
6. Place a few moisture-absorbing desiccant packs inside the electrical and control panel boxes.
7. Cover and place the machine in a dry area that is out of direct sunlight and away from hazardous fumes, paint, solvents, or gas. Fumes and sunlight can bleach or discolor paint and plastic parts.
8. At least once a month, start the mill and run all gear-driven components for a few minutes. This will keep the bearings, bushings, gears, and shafts well lubricated and protected from corrosion.

**Note:** If the machine will be out of service for only a short period of time, use way oil or a good grade of medium-weight machine oil (not auto engine oil) in place of the rust preventative.

## Adjusting Gibs

Gibs are tapered lengths of metal between two sliding surfaces. Gibs control the gap between these surfaces and how accurately they slide. Correctly adjusting the gibs is critical to producing good milling results.

Tight gibs make table movement more accurate but stiff. Loose gibs make moving the table sloppy but easier to do. The goal of gib adjustment is to remove unnecessary sloppiness without causing the ways to bind.

Gibs are adjusted with a screw on each end of the gib, that move the gib back and forth to increase or decrease the friction between the sliding surfaces. The process of properly adjusting the gibs requires trial-and-error and patience.

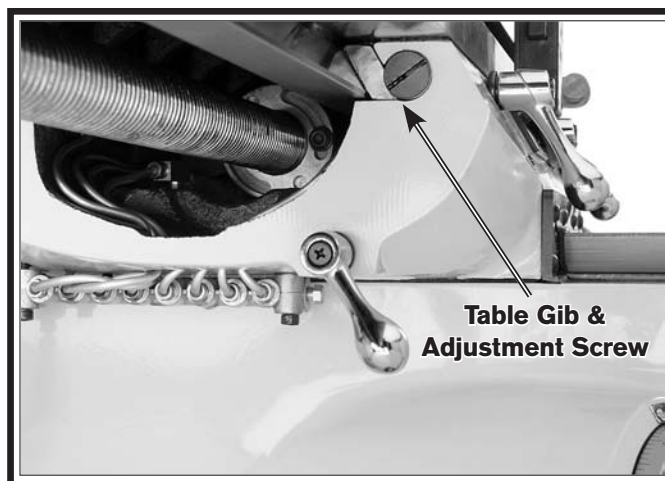
**DISCONNECT MILL FROM POWER BEFORE ADJUSTING THE GIBS!**

**Note:** The saddle and knee have three gibs each—two on each side, and one that is left of center. Adjust the gibs on the sides first, then adjust the left-center gib.

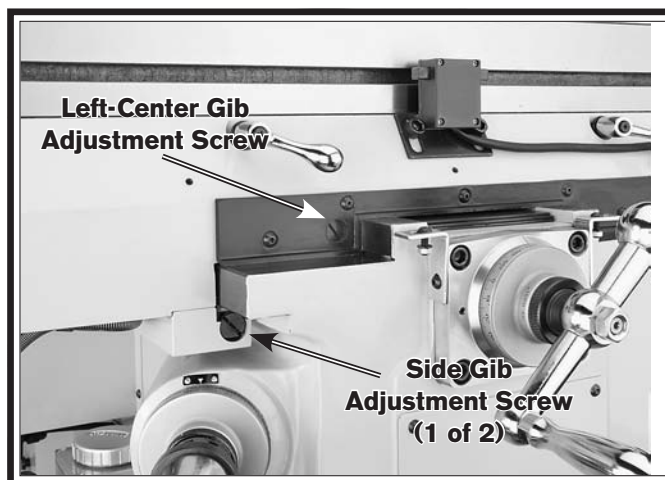
Make sure all table and knee locks are loose and that the table is centered on the saddle. Then, loosen one gib adjustment screw and tighten the other the same amount to move the gib. Use the handwheel/crank to move the table/knee until you feel a slight drag in that path of movement.

Refer to **Figures 60–62** to identify the locations of the table, saddle, and knee gibs, and one of the two adjustment screws for each.

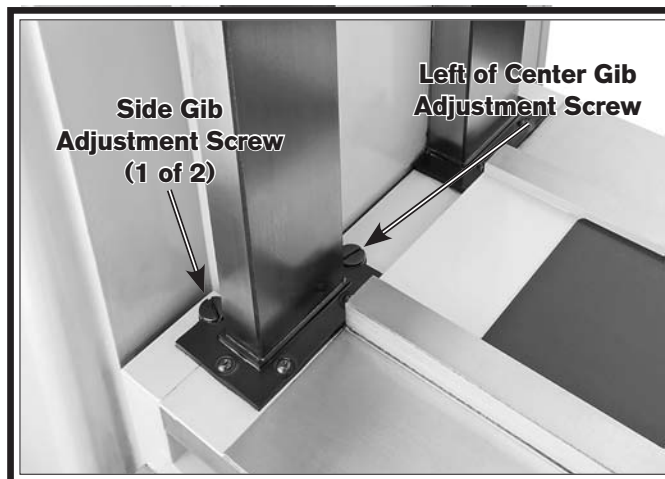
**Note:** It will be necessary to remove small parts, such as way wipers and covers, to access the gib adjustment screws.



**Figure 60.** Table gib and adjustment screw underneath the left side of the table.



**Figure 61.** Saddle gib adjustment screws.



**Figure 62.** Knee gib adjustment screws.

# Adjusting Leadscrew Backlash

Leadscrew backlash is the amount the leadscrew rotates before the attached device begins to move.

Although the mill is equipped with double-bronzed X-axis and Y-axis leadscrew nuts to minimize backlash, leadscrews will always have a certain amount of backlash that will increase with normal wear.

Generally, 0.005"–0.010" leadscrew backlash is acceptable to ensure smooth movement and reduce the risk of premature thread wear. However, if you find it necessary to adjust leadscrew backlash, perform the following procedures.

## X-Axis Leadscrew Backlash

Tools Needed	Qty
T-Handle Hex Wrench 5mm.....	1
Hex Wrench 8mm .....	1

### To adjust the X-axis leadscrew backlash:

1. DISCONNECT MILL FROM POWER!
2. Loosen the two cap screws on the leadscrew nut accessed from underneath the left side of the table, as shown in **Figure 63**.



**Figure 63. X-axis leadscrew nut and cap screw, as viewed from underneath the left side of the table.**

3. Use the T-handle hex wrench or a similar tool to rotate the adjustment plate on the leadscrew nut in small increments, then rotate the X-axis ball handle to check the amount of backlash.
4. When you are satisfied with the adjustment, re-tighten the two cap screws.

## Y-Axis Leadscrew Backlash

### Tools Needed

	Qty
T-Handle Hex Wrench 5mm.....	1
Hex Wrench 8mm .....	1
Wrench 19mm .....	1

### To adjust the Y-axis leadscrew backlash:

1. DISCONNECT MILL FROM POWER!
2. Remove the hex nut and ball handle from the Y-axis leadscrew.

**Note:** In the next step, take care not to misplace the leadscrew key as you remove the parts.

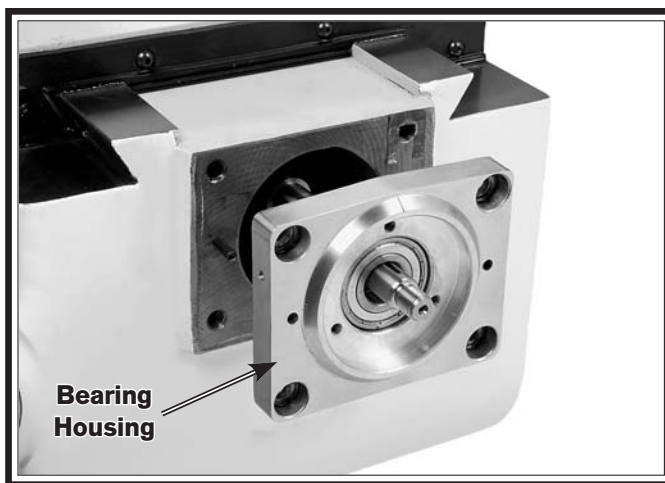
3. Unthread and remove the knurled retaining ring, graduated dial ring, and the leadscrew key, as shown in **Figure 64**.



**Figure 64.** Ball handle, rings, and key removed from the Y-axis leadscrew.

4. Remove the four cap screws from the bearing housing, then slide it off the leadscrew (see **Figure 65**).

**Note:** It may be necessary to use a dead blow hammer or rubber mallet on the housing to knock it loose.



**Figure 65.** Removing the bearing housing from the Y-axis leadscrew.

5. Loosen the two cap screws on the face of the leadscrew nut shown in **Figure 66**.



**Figure 66.** Y-axis leadscrew nut and cap screws.

6. Re-install the key onto the leadscrew so that you can use the ball handle in the next step.
7. Use the T-handle hex wrench or similar tool to rotate the adjustment plate on the leadscrew nut in small increments, then rotate the Y-axis ball handle to check the amount of backlash.
8. When you are satisfied with the adjustment, re-tighten the two cap screws.
9. Re-install the parts previously removed in the reverse order.

## Belt Tensioning

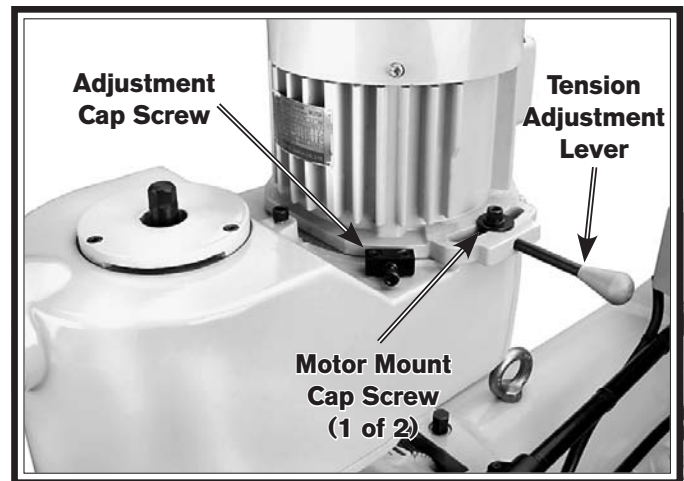
Power is transferred from the motor to the spindle with heavy-duty ribbed belts. With normal use, these belts will gradually stretch over time. When they do, perform the follow procedure to re-tension them.

### Tools Needed

	Qty
Hex Wrench 6mm .....	1
Hex Wrench 10mm .....	1

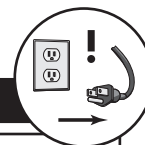
### To re-tension the belts:

1. DISCONNECT MILL FROM POWER!
2. Loosen the two motor mount cap screws, one on each side of the motor (see **Figure 67**).
3. Push the belt tension adjustment lever back with moderate force, then tighten the adjustment cap screw against the motor mounting plate to secure the setting.
4. Re-tighten the motor mount cap screws.

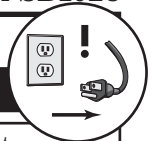


**Figure 67. Belt tensioning controls.**

If you need replacement parts, or if you are unsure how to do any of the solutions given here, feel free to call us at (360) 734-1540.



Symptom	Possible Cause	Possible Solution
Machine does not start or a breaker trips.	<ol style="list-style-type: none"> <li>Emergency stop button is pushed in or is at fault.</li> <li>Main power switch not turned <b>ON</b>.</li> <li>Plug/receptacle is at fault or wired incorrectly.</li> <li>Power supply is switched <b>OFF</b> or is at fault.</li> <li>Main power switch is at fault.</li> <li>Motor connection wired incorrectly.</li> <li>ON button or spindle direction switch at fault.</li> <li>Motor windings or motor is at fault.</li> </ol>	<ol style="list-style-type: none"> <li>Rotate the button clockwise until it pops out; replace if necessary.</li> <li>Make sure the electrical box door is closed and securely latched, then turn the main power switch <b>ON</b>.</li> <li>Test for good contacts; correct the wiring.</li> <li>Ensure hot lines have correct voltage on all legs and main power supply is switched <b>ON</b>.</li> <li>Replace the main power switch.</li> <li>Correct motor wiring connections (<b>Page 65</b>).</li> <li>Replace faulty ON button or spindle direction switch.</li> <li>Replace motor.</li> </ol>
Machine stalls or is overloaded.	<ol style="list-style-type: none"> <li>Machine is undersized for the task.</li> <li>Workpiece alignment is poor.</li> <li>Dull or incorrect cutting tool.</li> <li>Spindle speed is incorrect for the operation.</li> <li>Motor connection wired incorrectly.</li> <li>Plug/receptacle is at fault or wired incorrectly; incorrect voltage coming from power source.</li> <li>Pulley(s) slipping on shaft.</li> <li>Motor bearings at fault.</li> <li>Motor has overheated.</li> <li>Motor is at fault.</li> </ol>	<ol style="list-style-type: none"> <li>Use smaller or sharper tooling; reduce the feed rate; reduce the spindle speed; use coolant.</li> <li>Eliminate workpiece binding; use vise or clamps as required for proper workpiece alignment control.</li> <li>Use sharp and correct cutting tool for the operation.</li> <li>Select appropriate spindle speed (<b>Page 37</b>).</li> <li>Correct motor wiring connections (<b>Page 65</b>).</li> <li>Test for good contact; correct wiring problems; ensure hot lines have correct voltage on all legs.</li> <li>Replace loose pulley/shaft.</li> <li>Test by rotating shaft; rotation grinding/loose shaft requires bearing replacement.</li> <li>Clean off motor, let cool, and reduce workload.</li> <li>Replace motor.</li> </ol>
Machine has vibration or noisy operation.	<ol style="list-style-type: none"> <li>Tool holder or cutter is at fault.</li> <li>Workpiece alignment is poor.</li> <li>Motor or component is loose.</li> <li>Pulley is loose.</li> <li>Machine is incorrectly mounted to floor or sits uneven.</li> <li>Motor fan is rubbing on fan cover.</li> <li>Pulley(s) slipping on shaft.</li> <li>Motor bearings at fault.</li> <li>Gearbox is at fault.</li> </ol>	<ol style="list-style-type: none"> <li>Replace out-of-round tool holder; replace/re-sharpen cutter; use appropriate feed rate spindle speed.</li> <li>Eliminate workpiece binding; use vise or clamps as required for proper workpiece alignment control.</li> <li>Inspect replace stripped or damaged bolts/nuts and re-tighten with thread locking fluid.</li> <li>Re-align/replace shaft, pulley, set screw, and key as required.</li> <li>Re-tighten/replace mounting bolts in floor; relocate/shim machine.</li> <li>Replace dented fan cover or fan.</li> <li>Replace loose pulley/shaft.</li> <li>Test by rotating shaft; rotation grinding/loose shaft requires bearing replacement.</li> <li>Rebuild gearbox for bad gear(s)/bearing(s).</li> </ol>



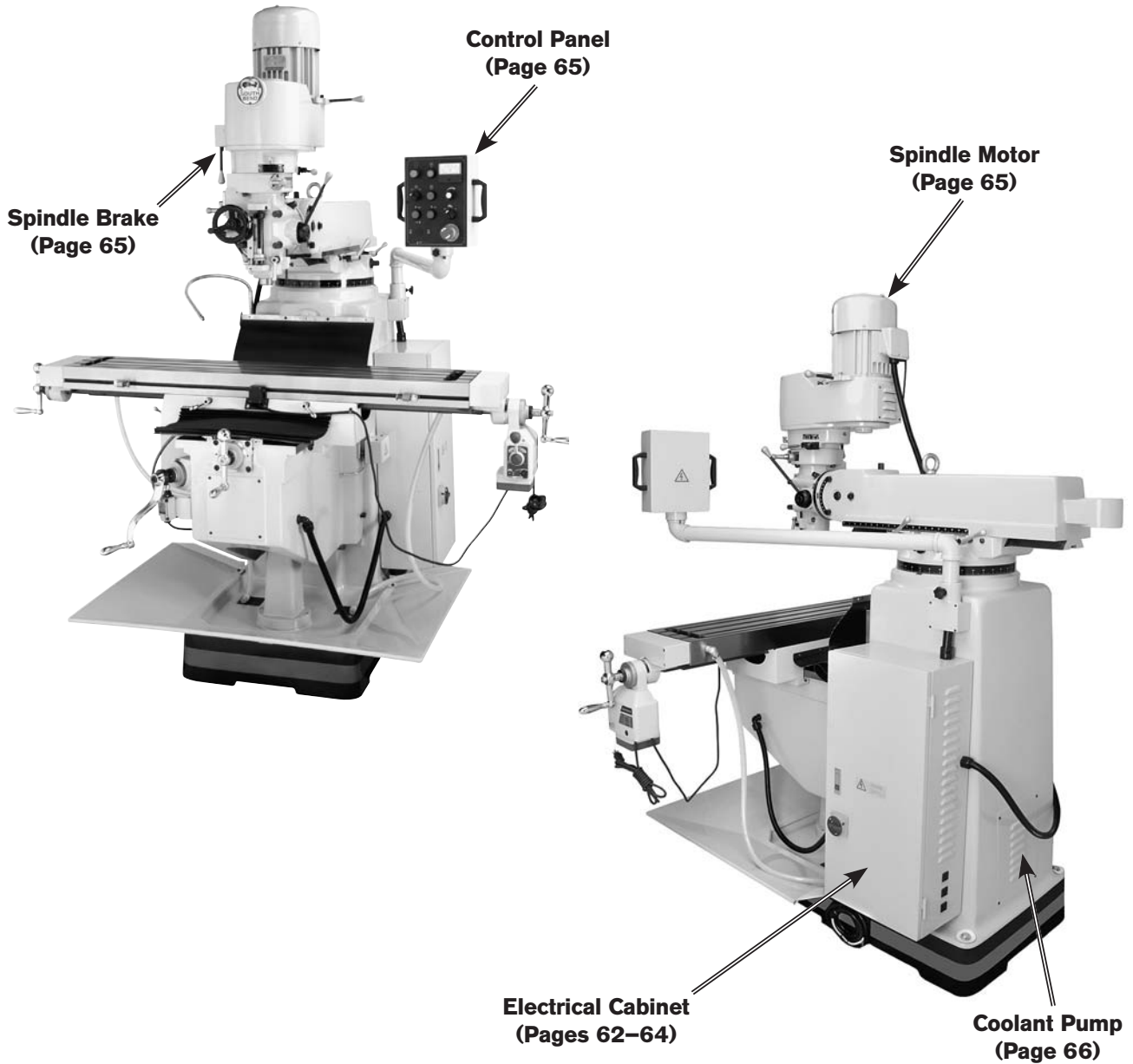
Symptom	Possible Cause	Possible Solution
Tool slips in collect.	<ol style="list-style-type: none"> <li>1. Collet is not fully drawn into spindle taper.</li> <li>2. Wrong size collet.</li> <li>3. Debris on mating surfaces of collet and spindle.</li> <li>4. Excessive depth of cut.</li> </ol>	<ol style="list-style-type: none"> <li>1. Snug up the drawbar to fully seat the collet.</li> <li>2. Use correct collect for tool shank diameter.</li> <li>3. Remove oil and debris from mating surfaces, then re-install.</li> <li>4. Decrease depth of cut and allow chips to clear.</li> </ol>
Tool breakage.	<ol style="list-style-type: none"> <li>1. Spindle speed too slow/feed rate too fast.</li> <li>2. Tool getting too hot.</li> <li>3. Excessive depth of cut.</li> </ol>	<ol style="list-style-type: none"> <li>1. Use correct spindle speed and feed rate (<b>Page 37</b>).</li> <li>2. Use coolant; reduce spindle speed/feed rate (<b>Page 37</b>).</li> <li>3. Decrease depth of cut and allow chips to clear.</li> </ol>
Workpiece chatters or vibrates during operation.	<ol style="list-style-type: none"> <li>1. Table/saddle/knee locks not tight.</li> <li>2. Workpiece not securely clamped to table or mill vise.</li> <li>3. Tool not secure or is damaged.</li> <li>4. Spindle speed too fast/feed rate too slow.</li> <li>5. Gibs are too loose.</li> </ol>	<ol style="list-style-type: none"> <li>1. Tighten all locks on mill that are not associated with necessary table movement for the operation.</li> <li>2. Check that clamping is tight and sufficient for the operation; make sure mill vise is clamped tight to table.</li> <li>3. Properly secure the tool; replace if damaged.</li> <li>4. Use correct spindle speed and feed rate (<b>Page 37</b>).</li> <li>5. Properly adjust gibs (<b>Page 54</b>).</li> </ol>
Table hard to move.	<ol style="list-style-type: none"> <li>1. Table/saddle/knee locks are tightened down.</li> <li>2. Chips have loaded up on the ways.</li> <li>3. Ways are dry and in need of lubrication.</li> <li>4. Gibs are too tight.</li> </ol>	<ol style="list-style-type: none"> <li>1. Fully loosen locks needed for movement.</li> <li>2. Frequently clean away chips from the ways that build up during operation.</li> <li>3. Use the one-shot oiler (<b>Page 47</b>).</li> <li>4. Properly adjust gibs (<b>Page 54</b>).</li> </ol>
Bad surface finish.	<ol style="list-style-type: none"> <li>1. Wrong spindle speed/feed rate.</li> <li>2. Dull/damaged tool; wrong tool for operation.</li> <li>3. Wrong spindle rotation direction for tool.</li> <li>4. Workpiece not securely clamped to table or mill vise.</li> <li>5. Gibs are too loose.</li> </ol>	<ol style="list-style-type: none"> <li>1. Use correct spindle speed and feed rate (<b>Page 37</b>).</li> <li>2. Sharpen/replace tool; use correct tool for operation.</li> <li>3. Check for proper spindle rotation direction for tool.</li> <li>4. Check that clamping is tight and sufficient for the operation; make sure mill vise is clamped tight to table.</li> <li>5. Properly adjust gibs (<b>Page 54</b>).</li> </ol>
Power feed chatters or grinds during operation.	<ol style="list-style-type: none"> <li>1. Brass bevel gear is not meshed with the drive gear.</li> <li>2. Power feed unit is at fault</li> </ol>	<ol style="list-style-type: none"> <li>1. Remove parts from the power feed side of the X-axis leadscrew to ensure the bevel gear is properly meshed; make sure the ball handle nut is tight.</li> <li>2. Replace.</li> </ol>

# Electrical Safety Instructions

These pages are accurate at the time of printing. In the constant effort to improve, however, we may make changes to the electrical systems of future machines. Study this section carefully. If you see differences between your machine and what is shown in this section, call Technical Support at (360) 734-1540 for assistance BEFORE making any changes to the wiring on the machine.

- 1. Shock Hazard:** It is extremely dangerous to perform electrical or wiring tasks while the machine is connected to the power source. Touching electrified parts will result in personal injury including but not limited to severe burns, electrocution, or death. For your own safety, disconnect machine from the power source before servicing electrical components or performing any wiring tasks!
- 2. Wire Connections:** All connections must be tight to prevent wires from loosening during machine operation. Double-check all wires disconnected or connected during any wiring task to ensure tight connections.
- 3. Modifications:** Using aftermarket parts or modifying the wiring beyond what is shown in the diagram may lead to unpredictable results, including serious injury or fire.
- 4. Motor Wiring:** The motor wiring shown in these diagrams is current at the time of printing, but it may not match your machine. Always use the wiring diagram inside the motor junction box.
- 5. Circuit Requirements:** Connecting the machine to an improperly sized circuit will greatly increase the risk of fire. To minimize this risk, only connect the machine to a power circuit that meets the minimum requirements given in this manual.
- 6. Capacitors/Inverters:** Some capacitors and power inverters store an electrical charge for up to 10 minutes after being disconnected from the power source. To reduce the risk of being shocked, wait at least this long before working on capacitors.
- 7. Wire/Component Damage:** Damaged wires or components increase the risk of serious personal injury, fire, or machine damage. If you notice that any wires or components are damaged while performing a wiring task, replace those wires or components before completing the task.
- 8. Experiencing Difficulties:** If you are experiencing difficulties understanding the information included in this section, contact our Technical Support at (360) 734-1540.

# Wiring Overview



## WIRING DIAGRAM COLOR KEY

BLACK — Bk —	BLUE WHITE — Bw —	RED — Rd —	PINK — Pk —	WHITE — Wt —
BLUE — Bl —	GREEN — Gn —	LIGHT BLUE — Lb —	PURPLE — Pu —	YELLOW GREEN — Yg —
BROWN — Br —	GRAY — Gy —	ORANGE — Or —	TUR-QUIOSE — Tu —	YELLOW — Yl —
BLACK GRAY — Bg —	GRAY BLACK — Gb —	GRAY WHITE — Gw —	LIGHT GREEN — Lg —	YELLOW BROWN — Yb —

**NOTICE:** The photos and diagrams included in this section are best viewed in color. You can see them in color at [www.southbendlathe.com](http://www.southbendlathe.com).

# Upper Electrical Cabinet Wiring

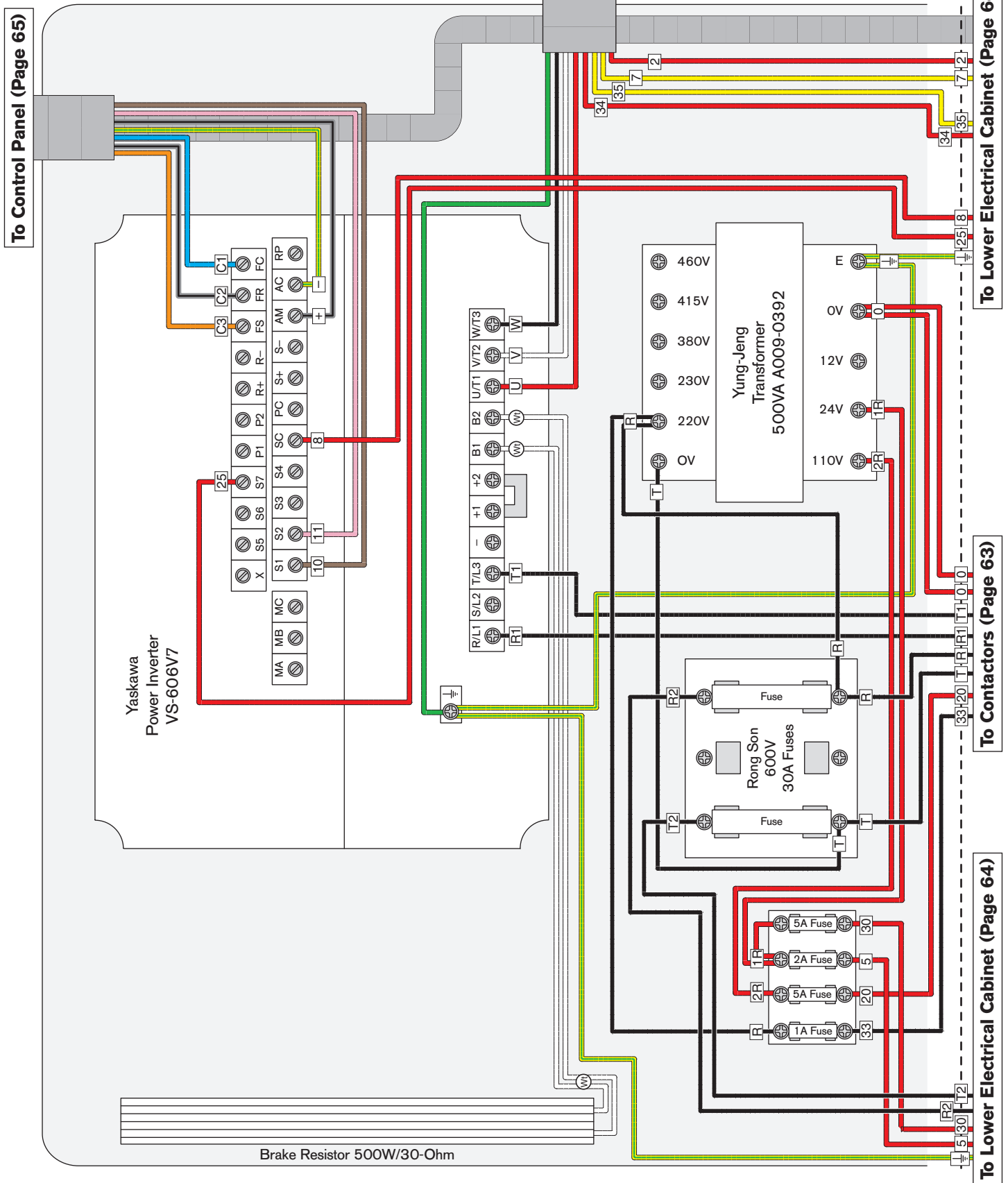
To Spindle Motor & Brake (Page 65)

To Control Panel (Page 65)

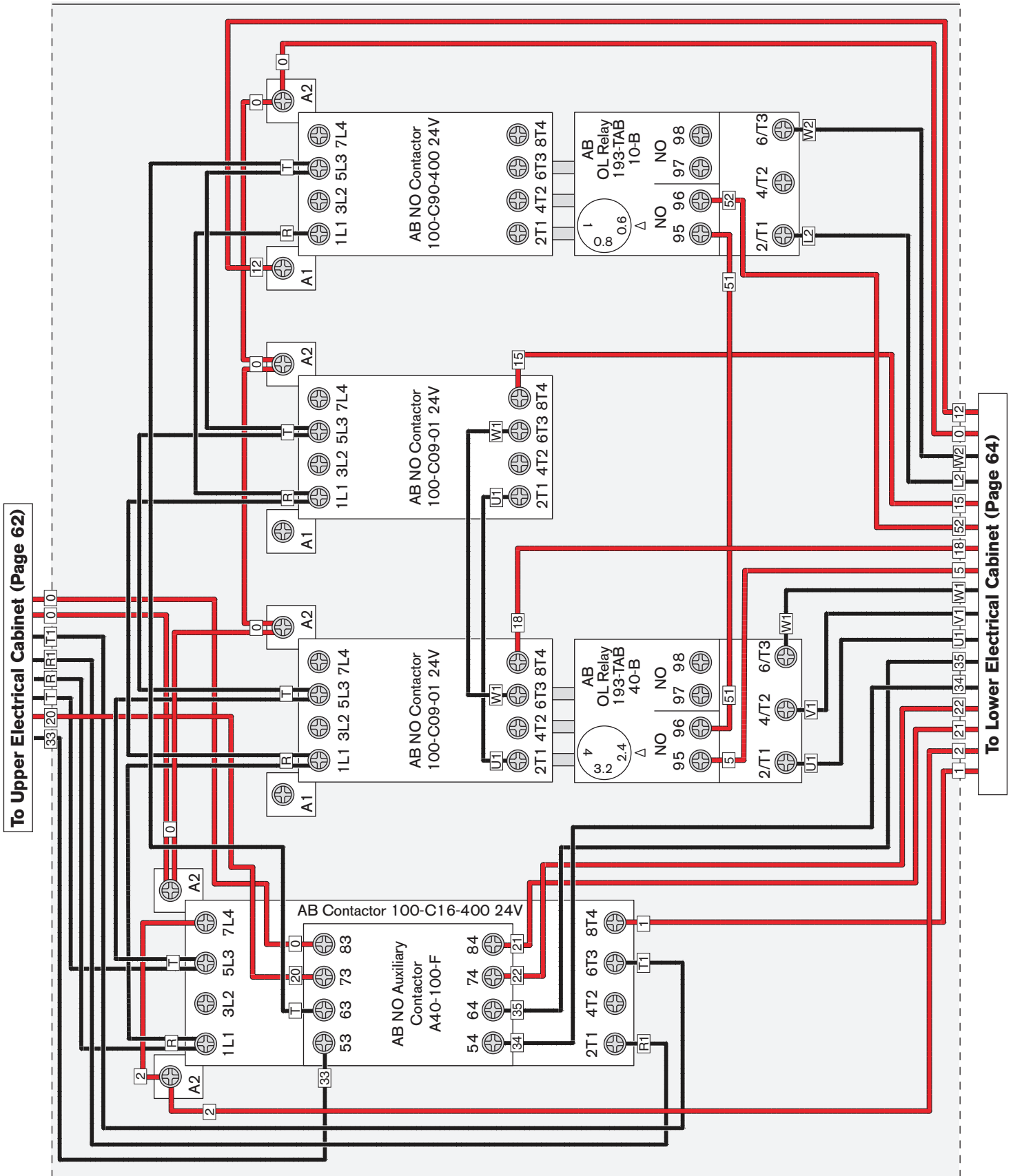
To Lower Electrical Cabinet (Page 64)

To Contactors (Page 63)

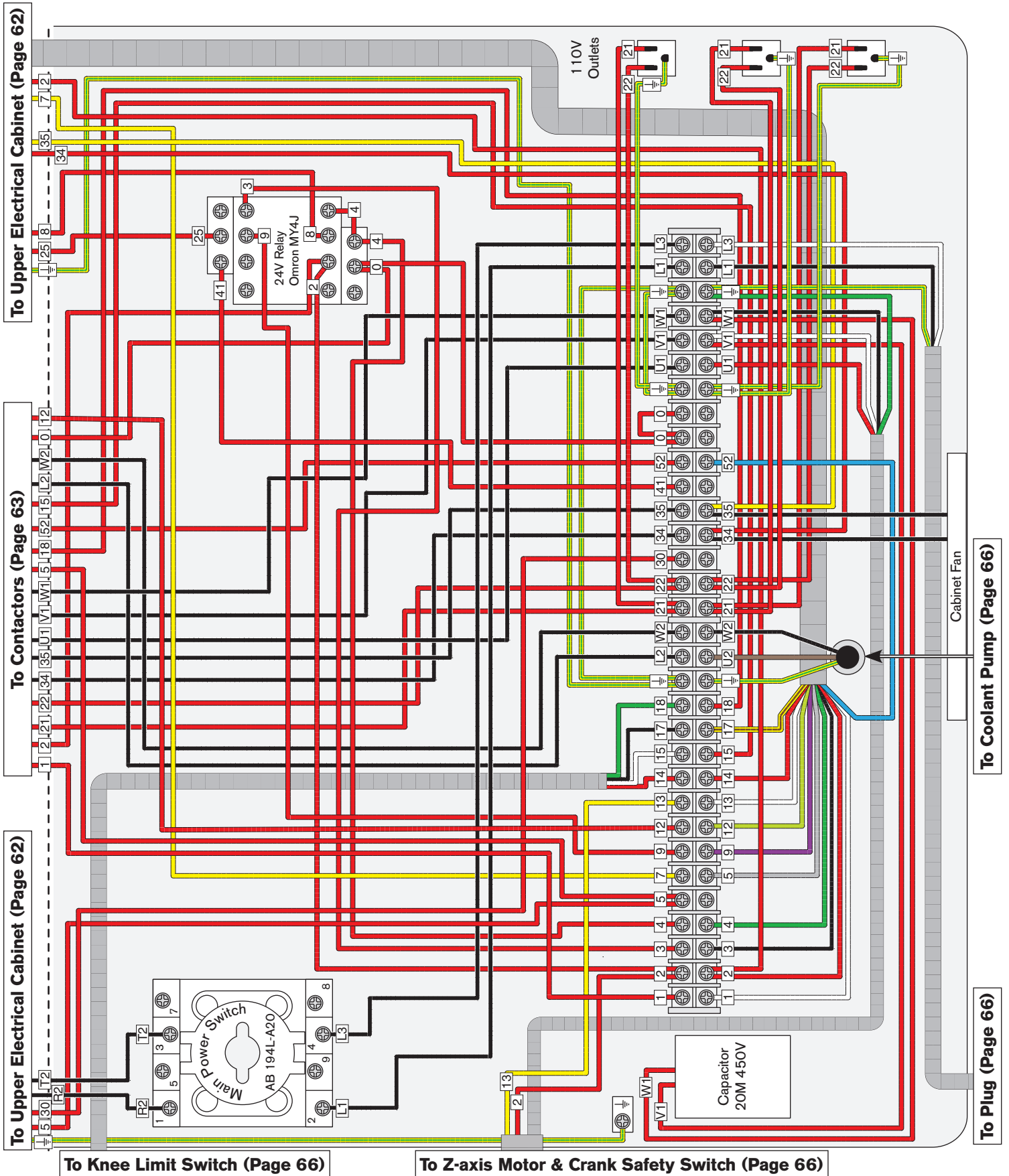
To Lower Electrical Cabinet (Page 64)



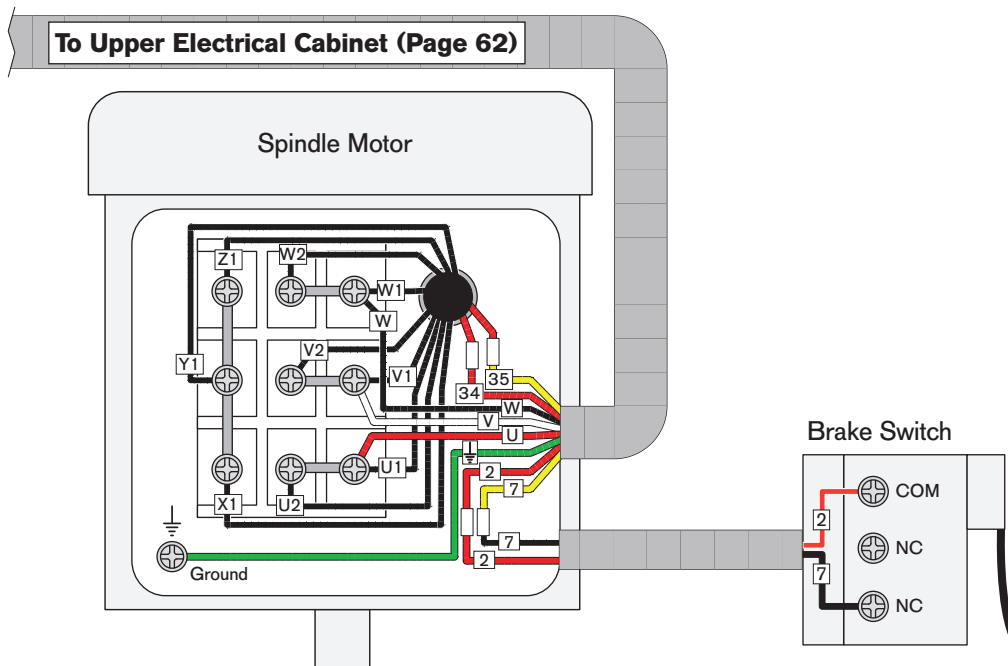
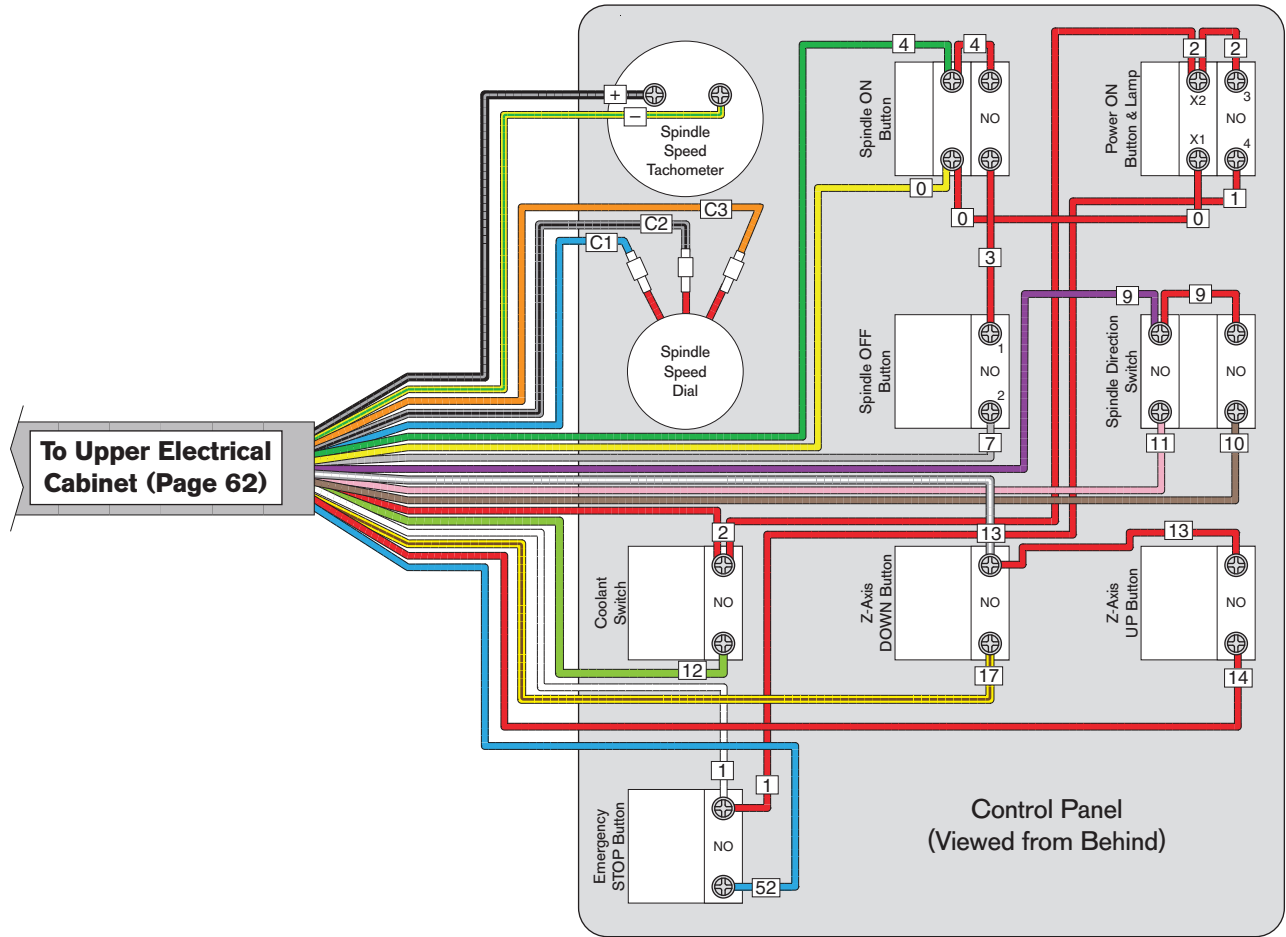
# Electrical Cabinet Contactors Wiring



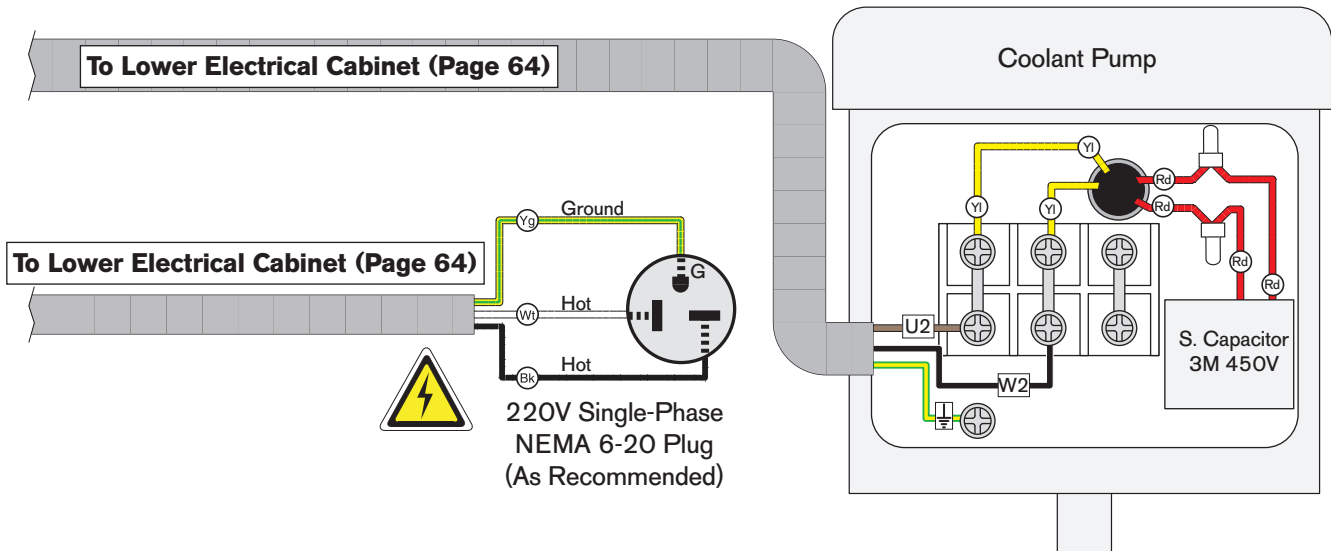
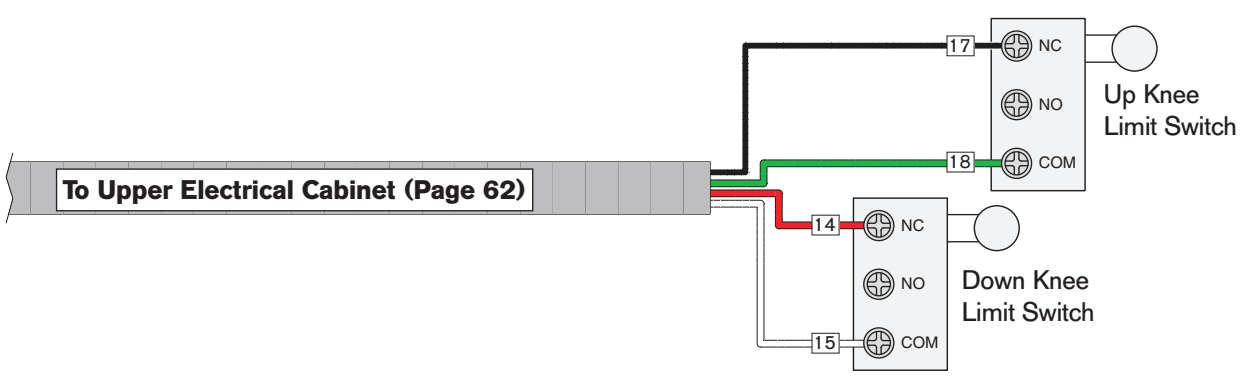
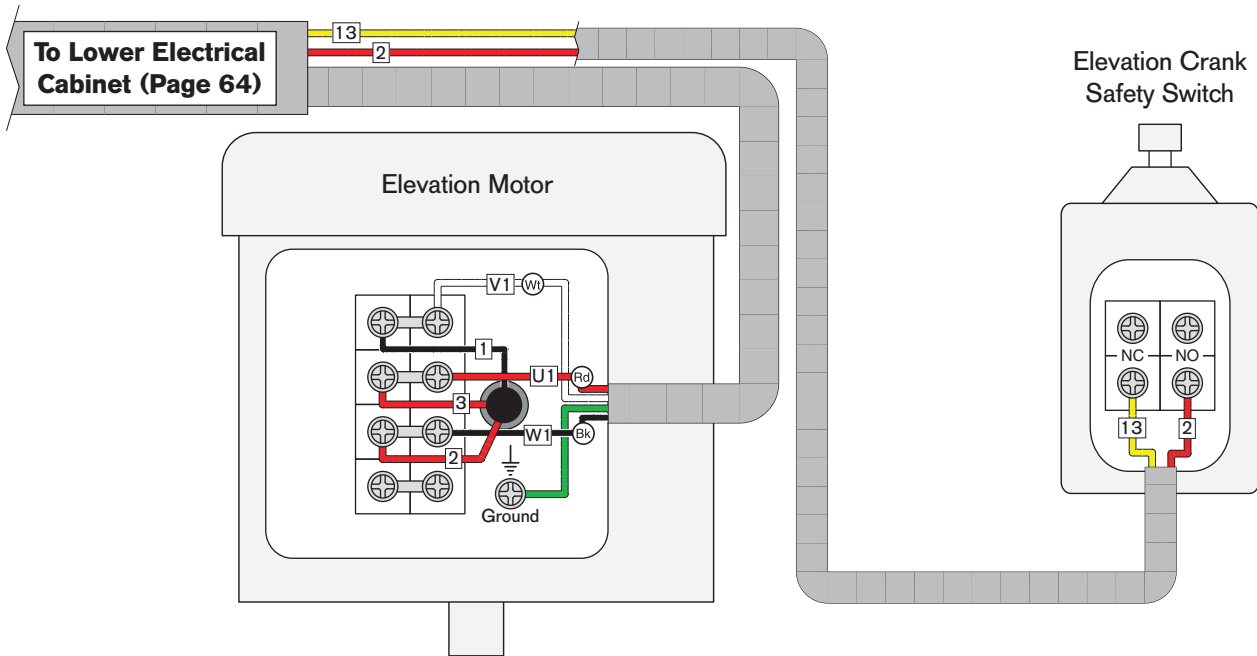
# Lower Electrical Cabinet Wiring



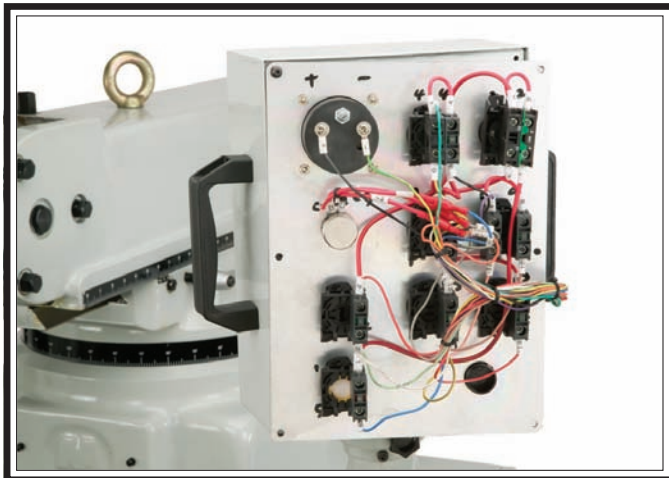
# Control Panel, Spindle Motor, & Brake Switch Wiring



# Other Electrical Components Wiring



# Electrical Component Pictures



**Figure 68. Control panel wiring.**



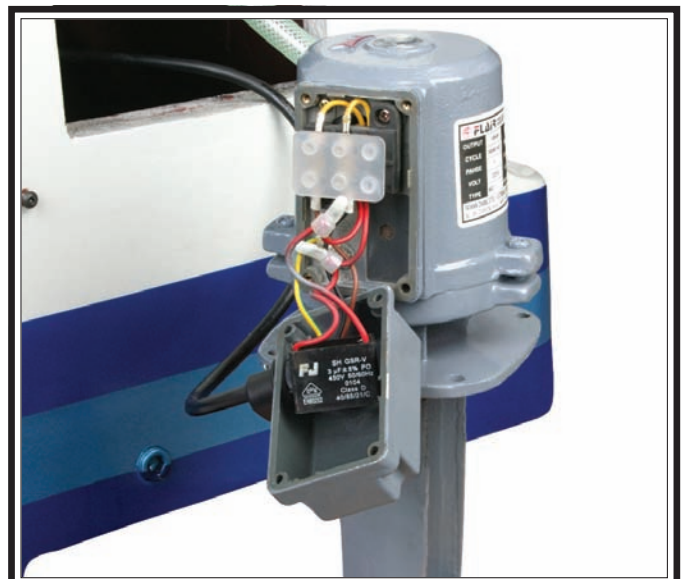
**Figure 70. Spindle motor wiring.**



**Figure 69. Electrical cabinet wiring.**

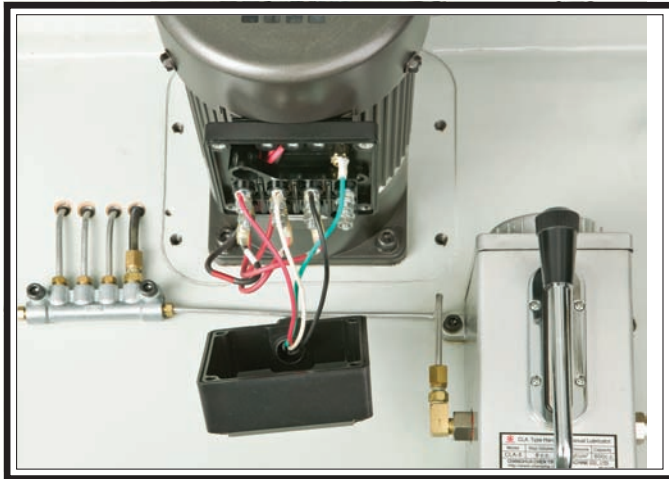


**Figure 71. Spindle brake switch wiring.**



**Figure 72. Coolant pump motor wiring.**

# Electrical Component Pictures



**Figure 73. Z-axis motor wiring.**



**Figure 75. Z-axis limit switches.**



**Figure 74. Z-axis crank safety switch.**



# Headstock Parts List

REF	PART #	DESCRIPTION
1	PSB10240449	ROUND KNOB 3/8-16
2	PSB10240002	COARSE DOWNFEED SHAFT LEVER
3	PSB10240003	COARSE DOWNFEED SHAFT HUB
4	PSTB004	STEEL BALL 3/16
5	PSB10240005	COMPRESSION SPRING
6	PSS05	SET SCREW 5/16-18 X 1/4
7	PSB10240007	HUB RETAINER
8	PSB10240008	PINION SHAFT HUB SLEEVE
9	PCAP33M	CAP SCREW M5-.8 X 12
10	PSB10240010	RETURN SPRING COVER
11	PSB10240011	FLAT COIL SPRING
12	PK155M	KEY 3 X 3 X 18
13	PSB10240013	RETURN SPRING STUD
14	PSB10240014	QUILL PINION GEAR SHAFT 10T/16T
15	PRIV001M	STEEL FLUTED RIVET 2 X 5MM
17	PSB10240017	ZERO SCALE
18	PSB10240018	ROUND KNOB 1/4-20
19	PSB10240019	SHIFT CRANK
20	PSS11	SET SCREW 1/4-20 X 1/4
21	PSB10240021	COMPRESSION SPRING
22	PSB10240022	GEAR SHIFT PLUNGER
23	PSB10240023	SHIFT SLEEVE
24	PSB10240024	WORM GEAR CRADLE THROW-OUT
25	PSB10240025	WORM SHAFT
26	PSS01M	SET SCREW M6-1 X 10
27	PK102M	KEY 4 X 4 X 18
28	PSB10240028	WORM
29	PSB10240029	CLUSTER GEAR RETAINER
30	PSB10240030	FEED CLUSTER GEAR 17T/28T/22T
31	PRO6M	EXT RETAINING RING 16MM
32	PSB10240032	BEVEL GEAR BUSHING
33	PSB10240033	BEVEL GEAR THRUST SPACER
34	PSB10240034	FEED REVERSE BEVEL PINION
35	PK53M	KEY 3 X 3 X 45
36	PSB10240037A	FEED ENGAGE PIN
37A	PSB10240037A	WORM GEAR CRADLE ASSEMBLY
37	PSB10240037A	WORM GEAR CRADLE
38	PSS26M	SET SCREW M5-.8 X 6
39	PCAP04M	CAP SCREW M6-1 X 10
40	PW03M	FLAT WASHER 6MM
41	PSB10240037A	WORM GEAR SPACER
42	PSB10240037A	FEED DRIVE WORM GEAR 20T
43	PSB10240037A	WORM CRADLE BUSHING
44	PK103M	KEY 3 X 3 X 12
45	PSB10240037A	FEED REVERSE BEVEL PINION
46	PCAP30	CAP SCREW 5/16-18 X 1/2
47	PSB10240037A	BEVEL GEAR FLAT WASHER 8MM
48	PSB10240037A	FEED BEVEL GEAR 24T
49	PK03M	KEY 3 X 3 X 8

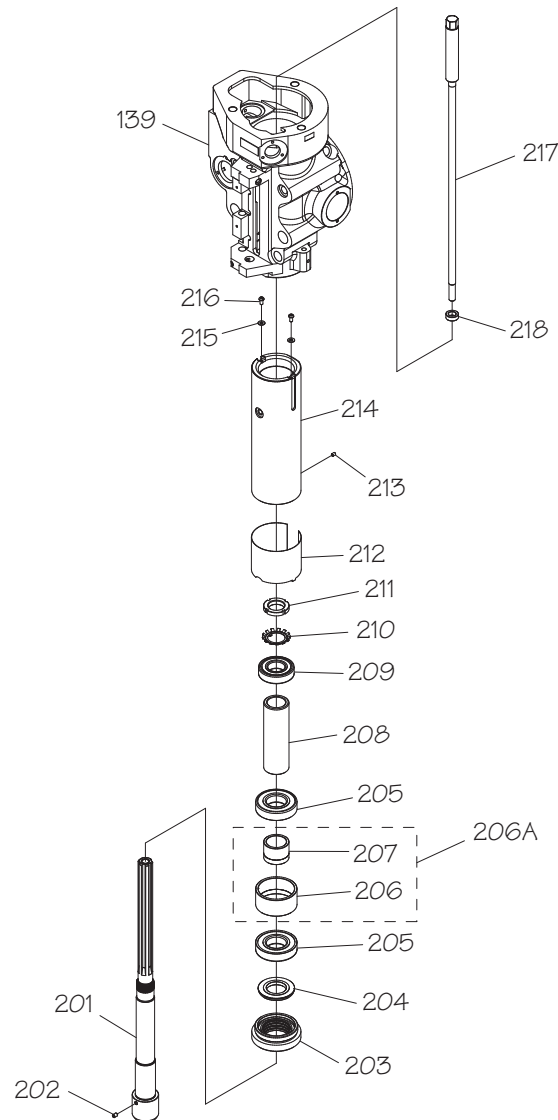
REF	PART #	DESCRIPTION
50	PSB10240037A	CLUSTER GEAR SHAFT 18T/12T
51	PSB10240037A	FEED DRIVE CLUSTER GEAR 23T
52	PSB10240037A	NEEDLE BEARING BZ66Z TIMKEN
53	PSB10240053	REVERSE CLUTCH ROD
54	PSB10240055A	FEED REVERSE BUSHING
55A	PSB10240055A	FEED REVERSE BEVEL GEAR ASSY
55	PSB10240055A	FEED REVERSE BUSHING
56	PSB10240056	FEED REVERSE CLUTCH
57	PRP42M	ROLL PIN 3 X 20
58	PRO3M	EXT RETAINING RING 12MM
59	PSB10240059	FEED WORM SHAFT BUSHING
60	PK39M	KEY 3 X 3 X 10
61	PK52M	KEY 3 X 3 X 15
62	PSB10240062	WORM
63	PSB10240063	BUSHING
64	PCAP06M	CAP SCREW M6-1 X 25
65	PSS01M	SET SCREW M6-1 X 10
66	PSB10240066	FEED GEAR SHIFTER FORK
67	PSB10240067	CLUSTER GEAR SHIFT CRANK
68	PSB10240068	FEED SHIFT ROD
69	PSB10240069	CLUSTER GEAR COVER
70	PSB10240070	QUILL PINION SHAFT BUSHING
71	PSB10280071	OVERLOAD CLUTCH WORM GEAR 30T
72	PRO5M	EXT RETAINING RING 15MM
73A	PSB10240073A	PINION OVERLOAD CLUTCH ASSY
73	PSB10240073A	PINION OVERLOAD CLUTCH SHAFT
74	PSB10240073A	OVERLOAD CLUTCH
75	PSB10240073A	CLUTCH COMPRESSION SPRING
76	PSS05M	SET SCREW M5-.8 X 10
77	PSB10240073A	PINION OVERLOAD CLUTCH COLLAR
78	PSB10240078	CLUTCH RING
79	PSB10240079	OVERLOAD CLUTCH WASHER
80	PRO1M	EXT RETAINING RING 10MM
81	PSB10240081	CLUTCH RING SCREW
82	PSB10240082	OVERLOAD CLUTCH TRIP LEVER
83	PRP03M	ROLL PIN 5 X 20
84	PSB10240084	CLUTCH ARM COVER
85	PCAP79M	CAP SCREW M5-.8 X 35
86	PN05	HEX NUT 1/4-20
87	PSS06	SET SCREW 1/4-20 X 3/4
88	PSB10240088	COMPRESSION SPRING
89	PSB10240089	OVERLOAD CLUTCH PLUNGER
90	PSB10240090	OIL CUP 1/8"
91	PSB10240091	TRIP PLUNGER BUSHING
92	PSB10240092	FEED TRIP PLUNGER
93	PSB10240093	FEED TRIP LEVER
94	PSB10240094	TRIP LEVER PIN
95	PN04M	HEX NUT M4-.7
96	PSS49M	SET SCREW M4-.7 X 16

# Headstock Parts List

REF	PART #	DESCRIPTION
97	PSB10240097	INDICATOR ROD LOCK KNOB
98	PSB10240098	INDICATOR ROD
99	PSB10240099	REVERSE TRIP BALL LEVER SCREW
100	PSB10240100	FEED REVERSE TRIP PLUNGER
101	PSB10240101	REVERSE TRIP BALL LEVER
102	PSB10240102	QUILL STOP DOG
103	PSB10240105A	QUILL MICRO STOP
104	PSB10240105A	MICRO STOP LOCK RING
105A	PSB10240105A	QUILL MICRO STOP ASSEMBLY
105	PSB10240105A	QUILL MICRO STOP SHAFT
106	PCAP105	CAP SCREW 3/8-16 X 5/8
107A	PSB10240107A	STOP TRIP BAR ASSEMBLY
107	PSB10240107A	STOP SHAFT TRIP BAR
108	PSB10240107A	COMPRESSION SPRING
109	PSB10240107A	STOP SHAFT TRIP SHAFT
110	PRP61M	ROLL PIN 3 X 12
111	PSB10240107A	STOP SHAFT END CAP
112	PRPO2M	ROLL PIN 3 X 16
113	PSB10240107A	TRIP BAR SET SCREW
114	PSB10240107A	STOP SHAFT PLUNGER
115	PSB10240115	FEED TRIP BRACKET
116	PCAP02M	CAP SCREW M6-1 X 20
117	PSB10240117	STOP SHAFT TRIP LEVER
118	PSB10240118	HANDWHEEL CLUTCH

REF	PART #	DESCRIPTION
119	PSTB004M	STEEL BALL 5MM
120	PSB10240120	COMPRESSION SPRING
121	PS517M	SET SCREW M8-1.25 X 6
122	PSB10240122	QUILL DEPTH SCALE
123	PS17M	PHLP HD SCR M4-.7 X 6
124	PSB10240124	FINE DOWNFEED HANDWHEEL
125	PSB10240124	HANDWHEEL HANDLE
126	PEC13M	E-CLIP 5MM
127A	PSB10240127A	KNURLED SLEEVE ASSEMBLY
127	PSB10240127A	KNURLED SLEEVE
128	PSB10240127A	HANDWHEEL CAPTIVE PIN
129	PSB10240129	QUILL LOCK NUT
130	PSB10240130	QUILL LOCK SLEEVE
131	PSB10240133A	LOCK SHAFT
132	PSB10240133A	TAPERED COMPRESSION SPRING
133A	PSB10240133A	LOCK HANDLE ASSEMBLY
133	PSB10240133A	LOCK HANDLE
134	PSB10240133A	LOCK HANDLE STEP SCREW
135	PSB10240135	HEAD ROTATION LOCK BOLT
136	PSB10240136	LOWER CLAMPING BOLT SPACER
137	PSB10240137	LOCK BOLT FLAT WASHER
138	PSB10240138	LOCK BOLT HEX NUT
139	PSB10240139	QUILL HOUSING

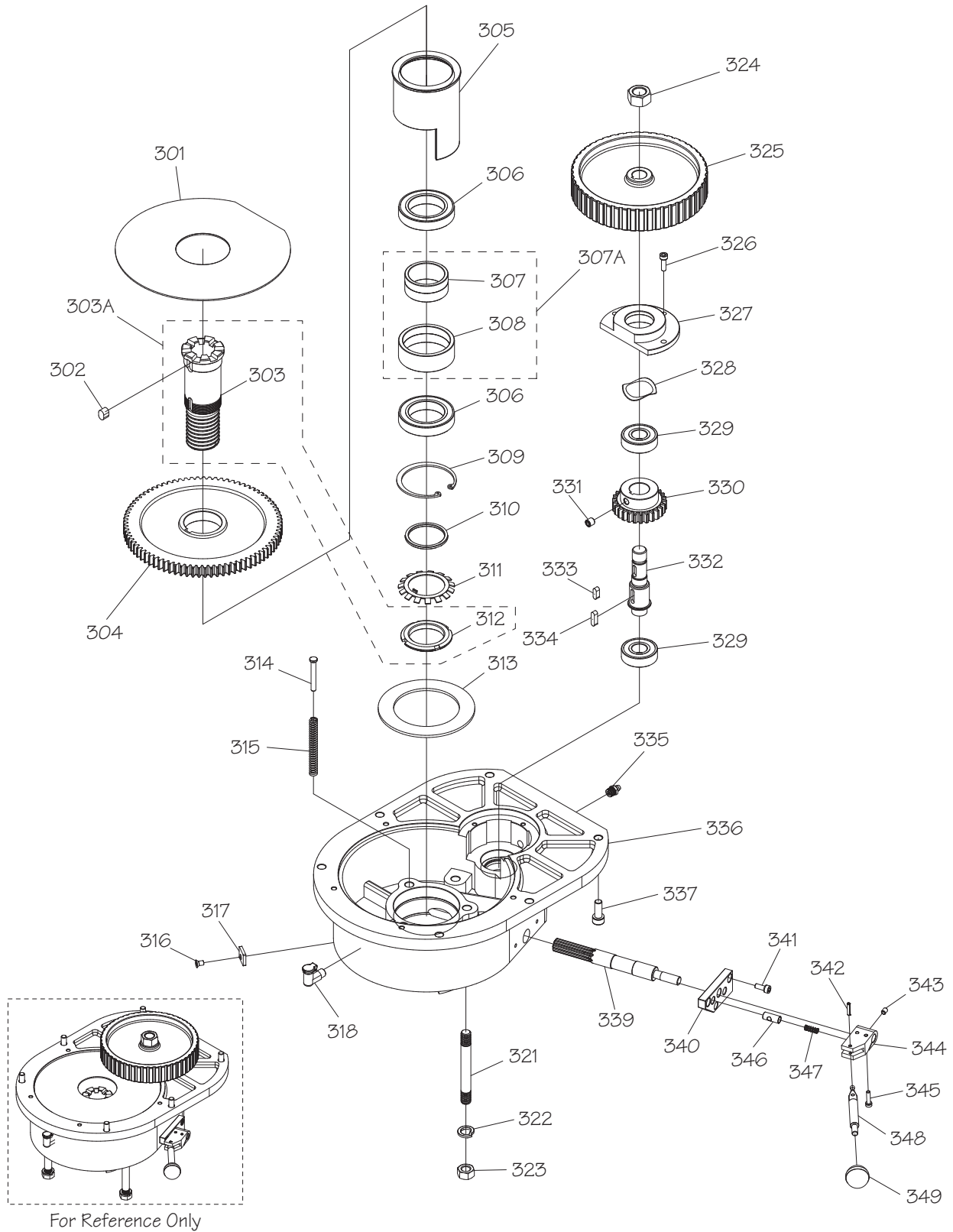
# Quill



REF	PART #	DESCRIPTION
139	PSB10240139	QUILL HOUSING
201	PSB10240201	SPINDLE R8
202	PS03M	SET SCREW M6-1 X8
203	PSB10240203	QUILL END CAP
204	PSB10240204	BEARING SEAL
205	P7207-P4	ANGULAR CONTACT BEARING 7207 P4
206A	PSB10240206A	BEARING SPACER ASSEMBLY
206	PSB10240206A	BEARING SPACER
207	PSB10240206A	BEARING BUSHING
208	PSB10240208	QUILL SLEEVE

REF	PART #	DESCRIPTION
209	P6206ZZ	BALL BEARING 6206ZZ
210	PSB10240210	SPANNER NUT LOCK WASHER
211	PSB10240211	SPANNER NUT
212	PSB10240212	QUILL SKIRT
213	PS526M	SET SCREW M5-.8 X 6
214	PSB10240214	QUILL
215	PW02M	FLAT WASHER 5MM
216	PS09M	PHLP HD SCR M5-.8 X 10
217	PSB10240217	DRAWBAR 1/2-20 X 23-3/8"
218	PSB10240218	DRAWBAR SPACER

# Gearbox

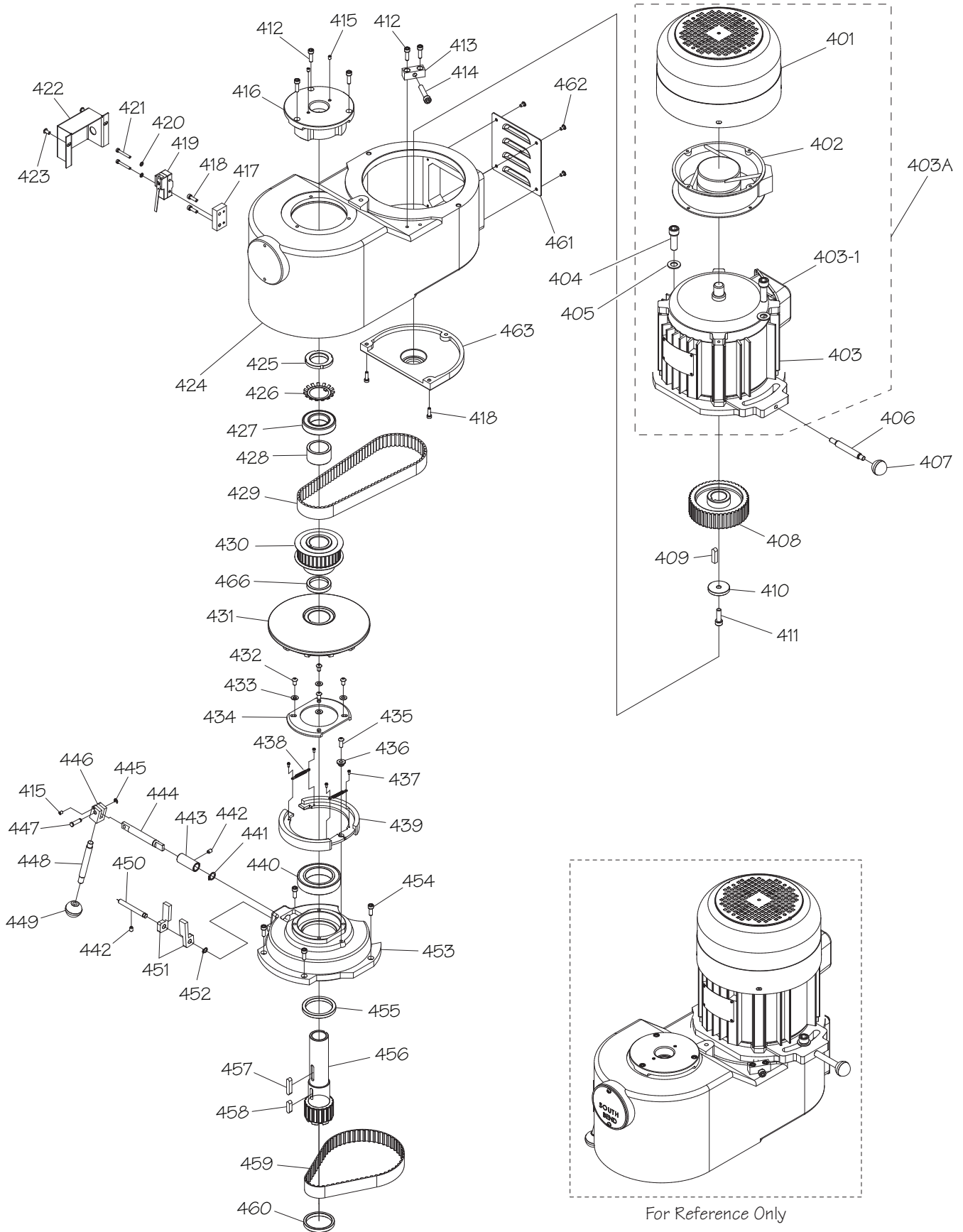


# Gearbox Parts List

REF	PART #	DESCRIPTION
301	PSB10240301	GEARBOX PLATE
302	PK70M	KEY 8 X 8 X 12
303A	PSB10240303A	SPINDLE GEAR HUB ASSEMBLY
303	PSB10240303A	SPINDLE GEAR HUB
304	PSB10240304	SPINDLE BULL GEAR
305	PSB10240305	BEARING SLEEVE
306	PSB10280306	BALL BEARING 6908V NSK
307A	PSB10240307A	BEARING SPACER ASSEMBLY
307	PSB10240307A	BULL GEAR BEARING SPACER
308	PSB10240307A	BULL GEAR BEARING SPACER
309	PR38M	INT RETAINING RING 62MM
310	PSB10240310	SPACER
311	PSB10240311	SPINDLE GEAR HUB
312	PSB10240303A	SPANNER NUT
313	PSB10240313	BEARING SLEEVE WASHER
314	PSB10240314	STEP PIN
315	PSB10240315	COMPRESSION SPRING
316	PFH71M	FLAT HD CAP SCR M5-.8 X 8
317	PSB10240317	BLOCK
318	PSB10240090	OIL CUP 1/8"
321	PSB10240321	DOUBLE-END STUD
322	PLW05	LOCK WASHER 7/16
323	PN19	HEX NUT 7/16-14
324	PN09	HEX NUT 5/8-11

REF	PART #	DESCRIPTION
325	PSB10240325	BELT PULLEY GEAR
326	PCAP24M	CAP SCREW M5-.8 X 16
327	PSB10240327	BULL GEAR PINION BEARING CAP
328	PSB10240328	WAVE SPRING WASHER
329	PSB10280329	BALL BEARING 6203V NSK
330	PSB10240330	PINION GEAR 30T
331	PSS20M	SET SCREW M8-1.25 X 8
332	PSB10240332	PINION GEAR SHAFT
333	PK19M	KEY 5 X 5 X 14
334	PK14M	KEY 5 X 5 X 18
335	PZERK005	GREASE FITTING ST 1/8 PT
336	PSB10240336	GEARBOX HOUSING
337	PCAP14M	CAP SCREW M8-1.25 X 20
339	PSB10240339	BULL GEAR SHIFT PINION SHAFT
340	PSB10240340	HI-LOW DETENT PLATE
341	PCAP33M	CAP SCREW M5-.8 X 12
342	PRP02M	ROLL PIN 3 X 16
343	PSS26M	SET SCREW M5-.8 X 6
344	PSB10240344	HI-LOW PINION BLOCK
345	PCAP16M	CAP SCREW M4-.7 X 16
346	PSB10240346	HIGH-LOW DETENT PLUNGER
347	PSB10240005	COMPRESSION SPRING
348	PSB10240348	HIGH-LOW LEVER
349	PSB10240018	ROUND KNOB 1/4-20

# Belt Housing

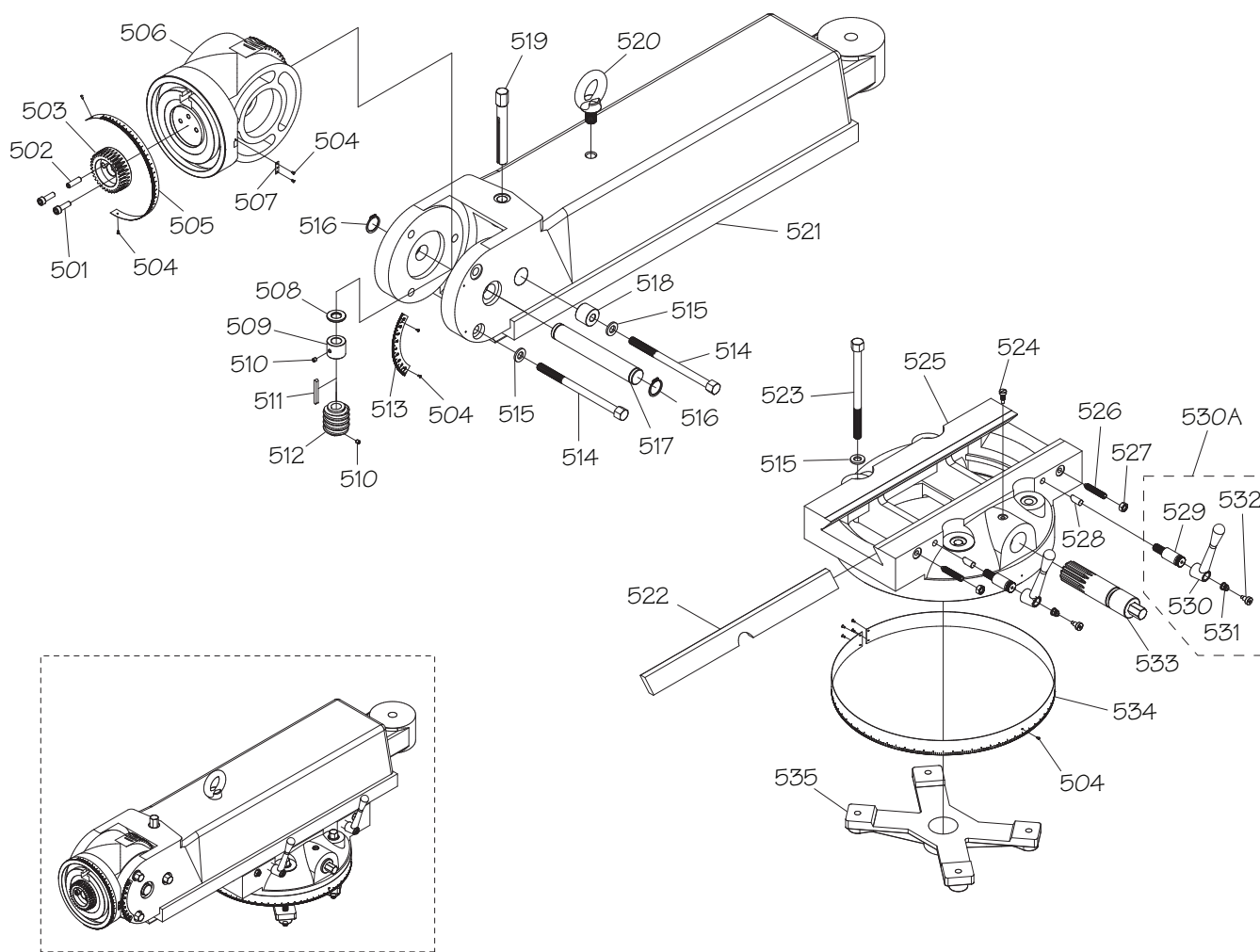


# Belt Housing Parts List

REF	PART #	DESCRIPTION
401	PSB10280403A	MOTOR FAN COVER
402	PSB10280403A	MOTOR FAN
403A	PSB10280403A	MOTOR ASSEMBLY
403	PSB10280403A	SPINDLE MOTOR 5HP 220V 3PH 60HZ
403-1	PSB10280403A	MOTOR JUNCTION BOX
404	PCAP111M	CAP SCREW M12-1.75 X 35
405	PW06M	FLAT WASHER 12MM
406	PSB10250403	BELT TENSION ADJUSTMENT LEVER
407	PSB10250407	KNOB 5/16-18
408	PSB10270408	MOTOR PULLEY
409	PK163M	KEY 8 X 7 X 30
410	PSB10270410	MOTOR PULLEY FLAT WASHER
411	PCAP31M	CAP SCREW M8-1.25 X 25
412	PCAP02M	CAP SCREW M6-1 X 20
413	PSB10270413	MOTOR ADJUSTMENT BLOCK
414	PCAP12M	CAP SCREW M8-1.25 X 40
415	PSS26M	SET SCREW M5-.8 X 6
416	PSB10270416	TOP BEARING COVER
417	PSB10270417	BRAKE SWITCH MOUNTING BLOCK
418	PCAP24M	CAP SCREW M5-.8 X 16
419	PSB10280419	BRAKE SWITCH
420	PW05M	FLAT WASHER 4MM
421	PCAP21M	CAP SCREW M4-.7 X 30
422	PSB10270422	BRAKE SWITCH COVER
423	PS09M	PHLP HD SCR M5-.8 X 10
424	PSB10270424	BELT HOUSING
425	PSB10270425	SPANNER NUT
426	PSB10270426	TABBED SPANNER LOCK WASHER
427	PSB10280427	BALL BEARING 6007V NSK
428	PSB10270428	BEARING SPACER
429	PSB10270429	TIMING BELT 800-8YU-25
430	PSB10270430	SPINDLE PULLEY
431	PSB10240438	BRAKE ASSEMBLY COVER

REF	PART #	DESCRIPTION
432	PS68M	PHLP HD SCR M6-1 X 10
433	PW03M	FLAT WASHER 6MM
434	PSB10240442	BRAKE BEARING CAP
435	PCAP115M	BUTTON HD CAP SCR M6-1 X 16
436	PSB10240444	BRAKE SHOE PIVOT SLEEVE
437	PS12M	PHLP HD SCR M3-.5 X 6
438	PSB10240446	BRAKE SHOE SPRING
439	PSB10240447	BRAKE SHOE SET
440	PSB10280440	BALL BEARING 6010W NSK
441	PR47M	EXT RETAINING RING 13MM
442	PSS03M	SET SCREW M6-1 X 8
443	PSB10280443	BRAKE SHAFT SLEEVE
444	PSB10240451	BRAKE SHAFT
445	PECO2M	E-CLIP 4MM
446	PSB10240453	BRAKE LEVER PIVOT BRACKET
447	PSB10280447	CAPTIVE PIN
448	PSB10240456	BRAKE LEVER
449	PSB10240449	ROUND KNOB 3/8-16
450	PSB10240458	BRAKE OPERATING FINGER
451	PSB10240459	BRAKE FINGER PIVOT STUD
452	PR36M	EXT RETAINING RING 7MM
453	PSB10240461	BRAKE SEAT
454	PCAP01M	CAP SCREW M6-1 X 16
455	PSB10240463	SPINDLE PULLEY SPACER
456	PSB10270456	SPINDLE PULLEY HUB
457	PK109M	KEY 7 X 7 X 35
458	PK27M	KEY 7 X 7 X 25
459	PSB10250447	TIMING BELT 225L-100
460	PSB10270460	SPINDLE PULLEY HUB COLLAR
461	PSB10240420	BELT HOUSING REAR COVER
462	PS05M	PHLP HD SCR M5-.8 X 8
463	PSB10270463	BELT HOUSING BOTTOM COVER
466	PSB10280466	PULLEY COLLAR

# Ram

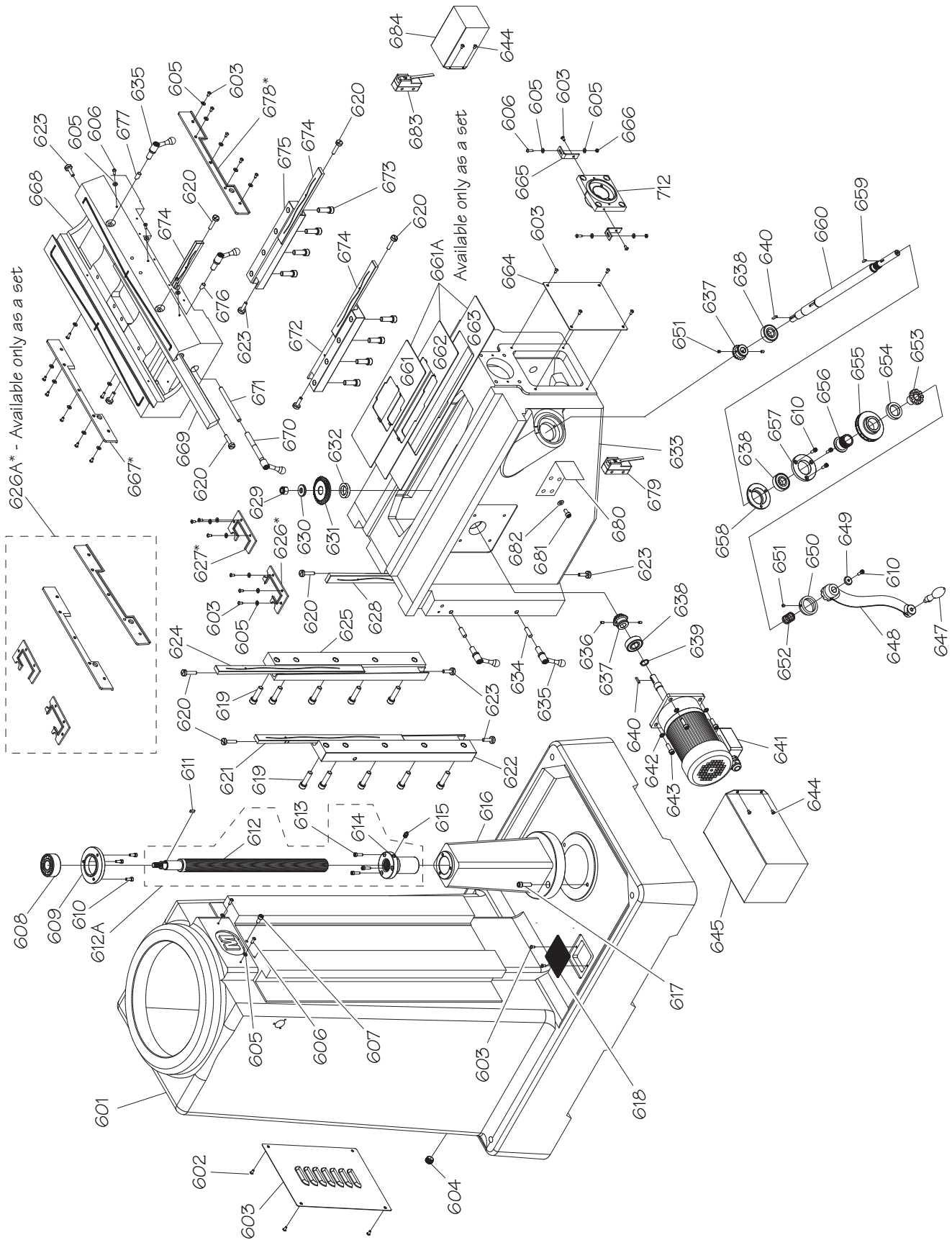


For Reference Only

REF	PART #	DESCRIPTION
501	PCAP31M	CAP SCREW M8-1.25 X 25
502	PSB10240502	DOWEL PIN 8 X 30
503	PSB10240503	GEAR 33T
504	PRIV001M	STEEL FLUTED RIVET 2 X 5MM
505	PSB10240505	HEAD ROTATION SCALE
506	PSB10240506	RAM ADAPTER
507	PSB10240017	ZERO INDICATOR
508	PSB10240508	WORM THRUST WASHER
509	PSB10240509	LOCK COLLAR
510	PSS02M	SET SCREW M6-1 X 6
511	PK36M	KEY 5 X 5 X 50
512	PSB10240512	HEAD TILT WORM
513	PSB10240513	HEAD TILT SCALE
514	PSB10280514	TILT LOCK BOLT
515	PW10M	FLAT WASHER 14MM
516	PR19M	EXT RETAINING RING 28MM
517	PSB10240517	TILT PIVOT STUD
518	PSB10240518	TILT LOCK BOLT BUSHING

REF	PART #	DESCRIPTION
519	PSB10240519	HEAD TILT WORM SHAFT
520	PSB10240520	EYE BOLT 3/4-10
521	PSB10280521	RAM
522	PSB10280522	RAM GIB
523	PSB10280523	TURRET CLAMP BOLT
524	PSB10240524	RAM PINION SCREW
525	PSB10280525	TURRET
526	PSB10240526	RAM GIB ADJUSTMENT SCREW
527	PN08	HEX NUT 3/8-16
528	PSB10240528	RAM LOCK PLUNGER
529	PSB10240530A	LOCK LEVER STUD
530A	PSB10240530A	RAM LOCK HANDLE ASSEMBLY
530	PSB10240530A	LOCK LEVER
531	PSB10240530A	COMPRESSION SPRING
532	PSB10240530A	STEP SCREW
533	PSB10240533	RAM PINION
534	PSB10240534	RAM ROTATION SCALE
535	PSB10240535	TURRET BRACKET

# Column, Knee, & Saddle

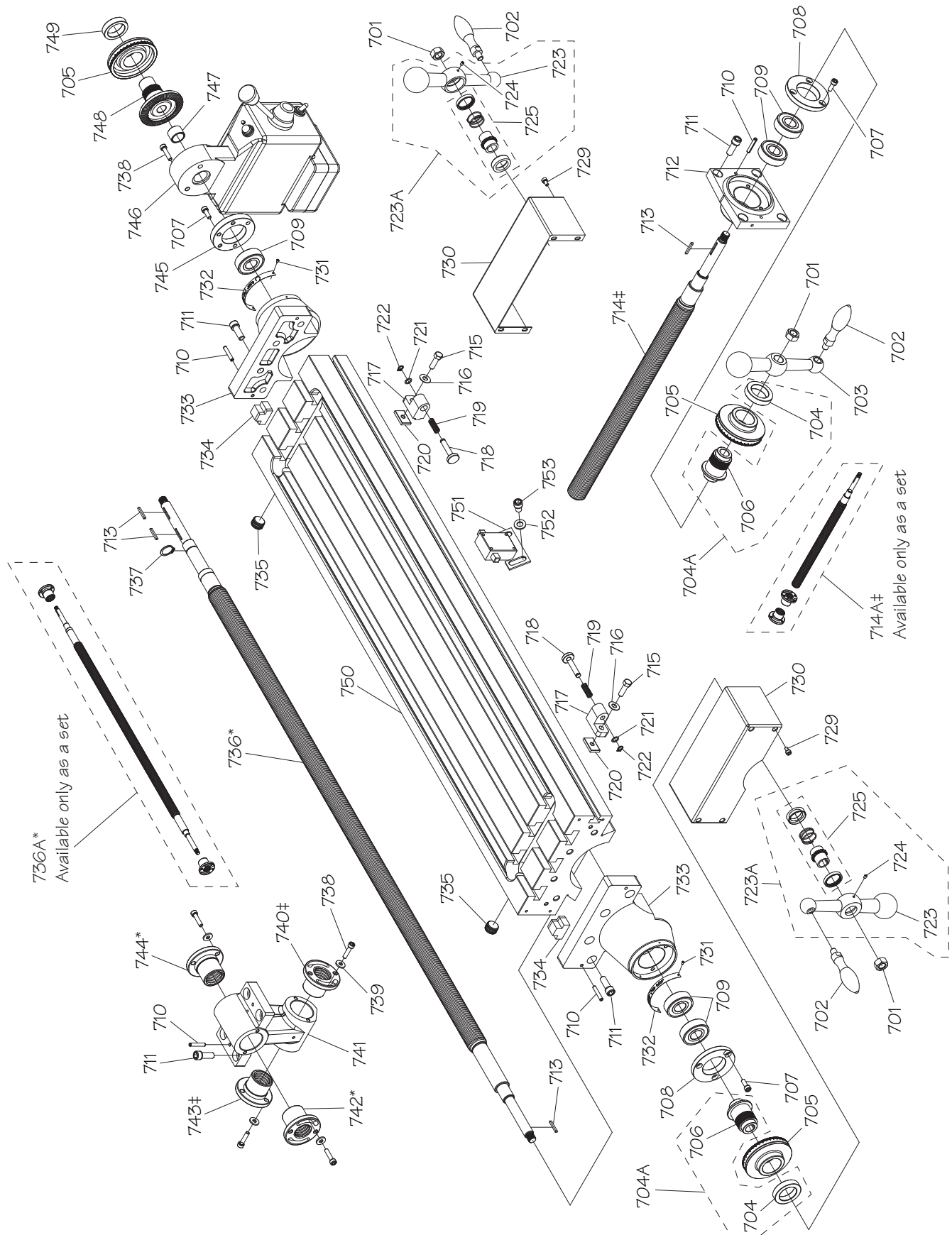


# Column, Knee, & Saddle Parts List

REF	PART #	DESCRIPTION
601	PSB10280601	COLUMN
602	PSB10240604	COOLANT RESERVOIR COVER
603	PS09M	PHLP HD SCR M5-.8 X 10
604	PSB10240606	COOLANT DRAIN PLUG 1/2" PT
605	PW02M	FLAT WASHER 5MM
606	PS40M	PHLP HD SCR M5-.8 X 16
607	PCAP11M	CAP SCREW M8-1.25 X 16
608	PSB10280608	DBL ANGULAR CONTACT BEARING 3305
609	PSB10280609	BEARING CAP
610	PCAP01M	CAP SCREW M6-1 X 16
611	PK20M	KEY 5 X 5 X 15
612A	PSB10280612A	ELEVATION LEADSCREW W/NUT ASSY
612	PSB10280612A	ELEVATION LEADSCREW
613	PCAP02M	CAP SCREW M6-1 X 20
614	PSB10280612A	ELEVATION LEADSCREW NUT
615	PZERK005	GREASE FITTING ST 1/8 PT
616	PSB10280616	ELEVATION LEADSCREW HOUSING
617	PCAP19	CAP SCREW 3/8-16 X 1-1/4
618	PSB10240625	COOLANT DRAIN SCREEN
619	PCAP108	CAP SCREW 1/2-13 X 1-3/4
620	PSB10240661	GIB ADJUSTMENT SCREW
621	PSB10280621	LEFT KNEE GIB
622	PSB10280622	LEFT KNEE GIB PLATE
623	PSB10240628	GIB PLATE SCREW
624	PSB10280624	RIGHT KNEE GIB
625	PSB10280625	RIGHT KNEE GIB PLATE
626A	PSB10280626A	KNEE/SADDLE WIPER SET
626	PSB10280626A	LEFT COLUMN WIPER
627	PSB10280626A	RIGHT COLUMN WIPER
628	PSB10280628	CENTER KNEE GIB
629	PN01	HEX NUT 1/2-20
630	PSB10240631	BEVEL GEAR FLAT WASHER 1/2
631	PSB10280631	BEVEL GEAR
632	PSB10280632	SPACER
633	PSB10280633	KNEE
634	PSB10280634	KNEE LOCK HANDLE PLUNGER
635	PSB10280635	KNEE LOCK HANDLE ASSEMBLY
636	PSS03M	SET SCREW M6-1 X 8
637	PSB10280637	BEVEL PINION
638	P6204ZZ	BALL BEARING 6204ZZ
639	PRO9M	EXT RETAINING RING 20MM
640	PK48M	KEY 4 X 4 X 20
641	PSB10280641	ELEVATION MOTOR 1/2HP 220V 1PH
642	PLW04M	LOCK WASHER 8MM

REF	PART #	DESCRIPTION
643	PCAP31M	CAP SCREW M8-1.25 X 25
644	PS05M	PHLP HD SCR M5-.8 X 8
645	PSB10280645	ELEVATION MOTOR COVER
647	PSB10240635	CRANK HANDLE
648	PSB10240636	ELEVATION CRANK
649	PW03M	FLAT WASHER 6MM
650	PSB10280650	CRANK BUSHING
651	PSS02M	SET SCREW M6-1 X 6
652	PSB10280652	COMPRESSION SPRING
653	PSB10280653	ELEVATION SHAFT CLUTCH
654	PSB10240638	FRONT DIAL RETAINER
655	PSB10240639	VERTICAL DIAL INCH
656	PSB10240640	REAR DIAL RETAINER
657	PSB10240642	BEARING RETAINER
658	PSB10240644	BEARING SEAT
659	PK47M	KEY 4 X 4 X 15
660	PSB10280660	ELEVATION SHAFT
661A	PSB10280661A	CHIP GUARD SET
661	PSB10280661A	SMALL CHIP GUARD
662	PSB10280661A	MEDIUM CHIP GUARD
663	PSB10280661A	LARGE CHIP GUARD
664	PSB10280664	KNEE FRONT COVER
665	PSB10240654	WAY COVER SUPPORT
666	PN06M	HEX NUT M5-.8
667	PSB10280626A	REAR SADDLE WIPER
668	PSB10280668	SADDLE
669	PSB10280669	TABLE GIB
670	PSB10280670	SADDLE LOCK HANDLE ASSEMBLY
671	PSB10280671	SADDLE LOCK PLUNGER
672	PSB10280672	LEFT SADDLE GIB PLATE
673	PCAP111M	CAP SCREW M12-1.75 X 35
674	PSB10280674	SADDLE GIB
675	PSB10280675	RIGHT SADDLE GIB PLATE
676	PSB10280676	LEFT TABLE LOCK HANDLE PLUNGER
677	PSB10280677	RIGHT TABLE LOCK HANDLE PLUNGER
678	PSB10280626A	FRONT SADDLE WIPER
679	PSB10280679	ELEVATION CRANK SAFETY SWITCH
680	PSB10280680	SAFETY SWITCH BRACKET
681	PCAP33M	CAP SCREW M5-.8 X 12
682	PW02M	FLAT WASHER 5MM
683	PSB10280683	KNEE SAFETY SWITCH
684	PSB10280684	SAFETY SWITCH COVER
712	PSB10240712	CROSS FEED BEARING BRACKET

# Table



736A\*  
Available only as a set

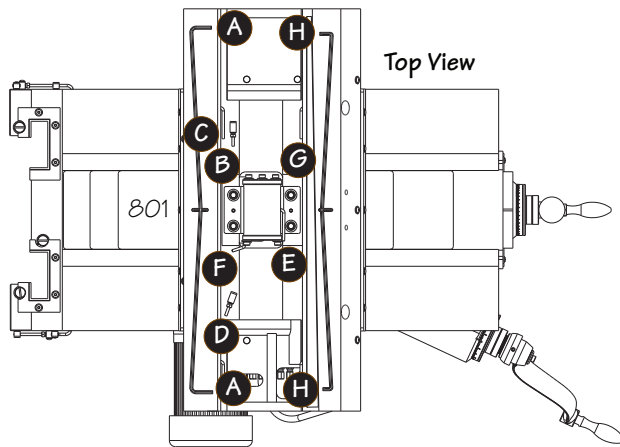
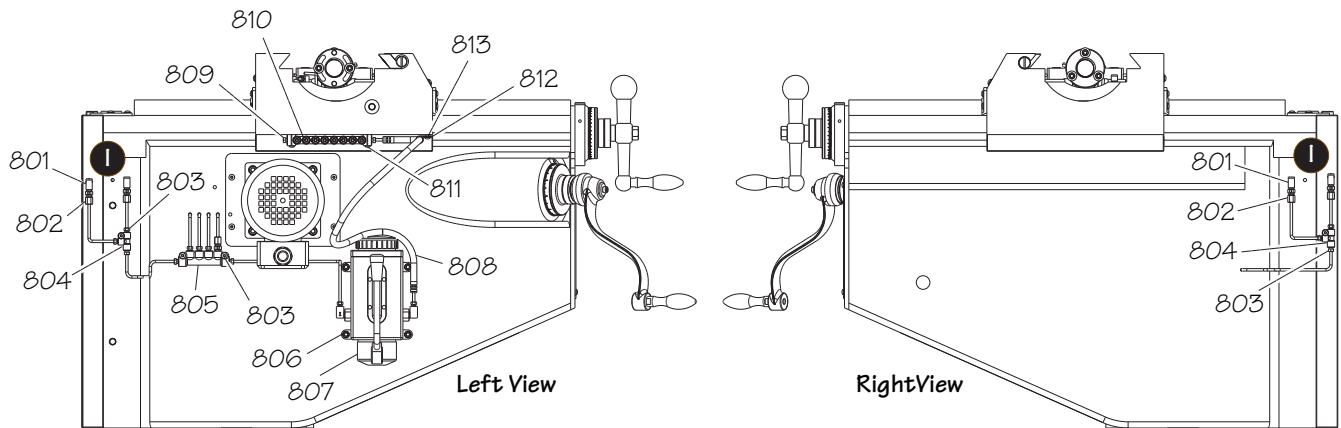
714A\*  
Available only as a set

# Table Parts List

REF	PART #	DESCRIPTION
701	PNO1	HEX NUT 1/2-20
702	PSB10240635	BALL HANDLE KNOB
703	PSB10240703	CROSS FEED BALL HANDLE
704A	PSB10240704A	DIAL HOLDER ASSEMBLY
704	PSB10240704A	FRONT DIAL RETAINER
705	PSB10240705	TABLE DIAL INCH
706	PSB10240704A	INNER DIAL HOLDER
707	PCAP01M	CAP SCREW M6-1 X 16
708	PSB10240642	BEARING RETAINER
709	P6204ZZ	BALL BEARING 6204ZZ
710	PRPO5M	ROLL PIN 5 X 30
711	PCAP14	CAP SCREW 3/8-16 X 1
712	PSB10240712	CROSS FEED BEARING BRACKET
713	PK92M	KEY 3 X 3 X 25
714A	PSB10240714A	CROSS FEED LEADSCREW W/NUT ASSY
714	PSB10240714A	CROSS FEED LEADSCREW
715	PCAP03	CAP SCREW 5/16-18 X 1
716	PW07	FLAT WASHER 5/16
717	PSB10240717	TRAVEL STOP BRACKET
718	PSB10240718	TRAVEL STOP SHAFT
719	PSB10240719	COMPRESSION SPRING
720	PSB10240720	TRAVEL STOP T-NUT
721	PSB10240721	TRAVEL STOP FLAT WASHER 8MM
722	PR36M	EXT RETAINING RING 7MM
723A	PSB10240723A	LONGITUDINAL BALL HANDLE ASSEMBLY
723	PSB10240723A	LONGITUDINAL BALL HANDLE
724	PSS08M	SET SCREW M4-.7 X 5

REF	PART #	DESCRIPTION
725	PSB10240723A	BALL HANDLE CLUTCH ASSEMBLY
729	PCAP03M	CAP SCREW M5-.8 X 8
730	PSB10280730	TABLE BEARING BRACKET COVER
731	PRIV001M	STEEL FLUTED RIVET 2 X 5MM
732	PSB10270732	INDICATOR PLATE
733	PSB10270733	BEARING BRACKET
734	PSB10240730	RUBBER TABLE T-SLOT PLUG
735	PSB10240606	TABLE DRAIN PLUG 1/2" PT
736A	PSB10270736A	LONGITUDINAL LEADSCREW W/NUT ASSY
736	PSB10280736	LONGITUDINAL LEADSCREW
737	PRO9M	EXT RETAINING RING 20MM
738	PCAP06M	CAP SCREW M6-1 X 25
739	PW03M	FLAT WASHER 6MM
740	PSB10240714A	FRONT CROSS FEED LEADSCREW NUT
741	PSB10240736	LEADSCREW NUT BRACKET
742	PSB10270736A	LEFT LONGITUDINAL LEADSCREW NUT
743	PSB10240714A	REAR CROSS FEED LEADSCREW NUT
744	PSB10270736A	LEFT LONGITUDINAL LEADSCREW NUT
745	PSB10270745	BEARING RETAINING RING
746	PSB10240741	POWER FEED ASSEMBLY
747	PSB10240742	BEVEL GEAR BUSHING
748	PSB10240743	POWER FEED BEVEL GEAR
749	PSB10240744	BEVEL GEAR NUT
750	PSB10280750	TABLE 10" X 54"
751	PSB10240746	LONGITUDINAL LIMIT SWITCH ASSEMBLY
752	PW04M	FLAT WASHER 10MM
753	PCAP100	CAP SCREW 3/8-16 X 1/2

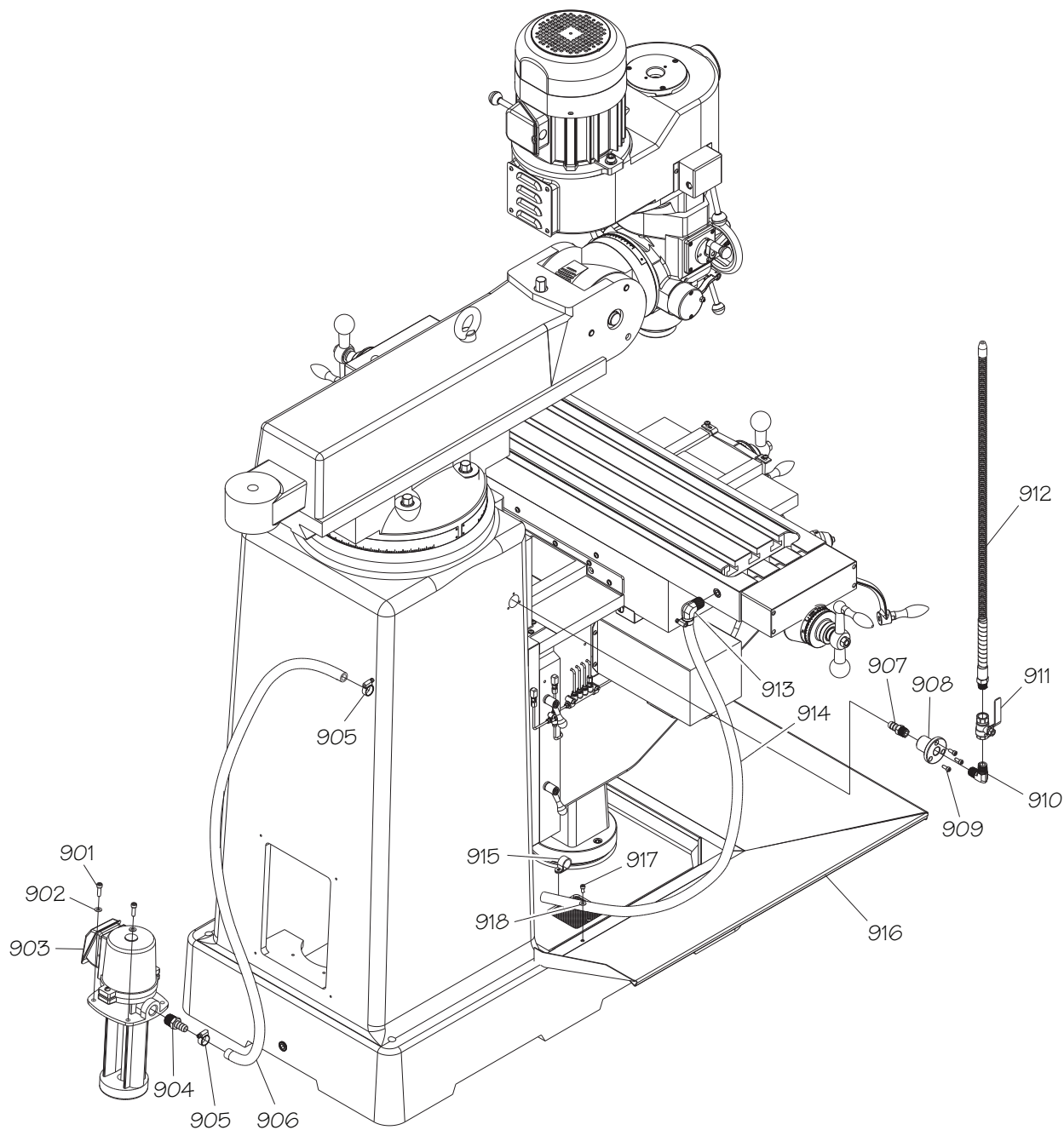
# One-Shot Oiler System



REF	PART #	DESCRIPTION
801	PSB10240801	ELBOW JOINT M4 X 1/8 PT
802	PSB10280802	STRAIGHT TUBE ADAPTER NO 3
803	PCAP06M	CAP SCREW M6-1 X 25
804	PSB10280804	TUBE T-ADAPTER 4 X 4MM
805	PSB10280805	OIL DISTRIBUTOR 4 PORT
806	PCAP02M	CAP SCREW M6-1 X 20
807	PSB10280807	ONE-SHOT OILER ASSEMBLY

REF	PART #	DESCRIPTION
808	PSB10280808	STEEL TUBE 4 X 600MM
809	PSB10280809	THREADED PLUG M8-1.25
810	PSB10280810	OIL DISTRIBUTOR 8 PORT
811	PCAP38M	CAP SCREW M5-.8 X 25
812	PSB10280812	TUBE CLIP
813	PS09M	PHLP HD SCR M5-.8 X 10

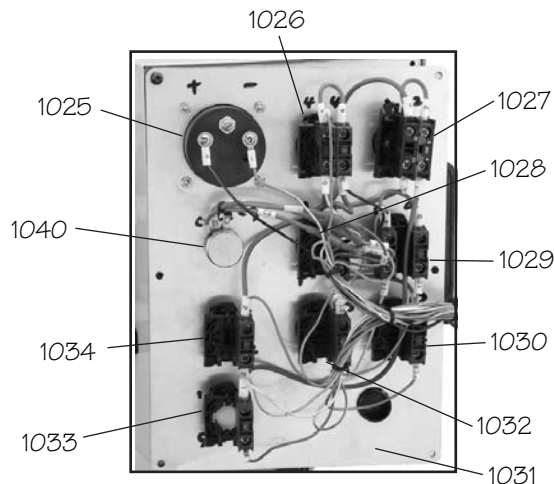
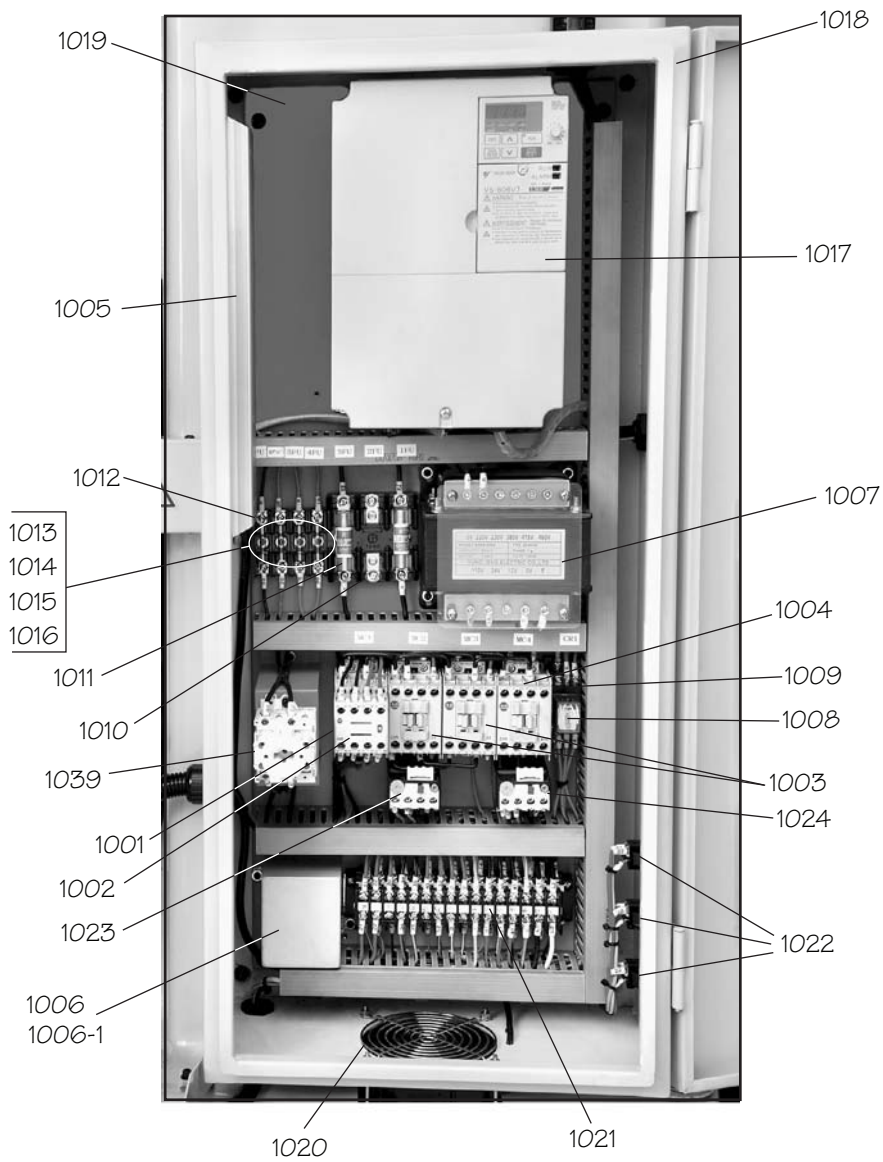
# Coolant System



REF	PART #	DESCRIPTION
901	PCAP02M	CAP SCREW M6-1 X 20
902	PW03M	FLAT WASHER 6MM
903	PSB10270903	COOLANT PUMP 1/8HP 220V 1PH 60HZ
904	PSB10270904	BARBED HOSE FITTING 3/8 PT X 1/2"
905	PSB10270905	THREADED HOSE CLAMP 3/4"
906	PSB10270906	COOLANT HOSE 1/2 X 43-1/2"
907	PSB10270904	BARBED HOSE FITTING 3/8 PT X 1/2"
908	PSB10270908	COOLANT NOZZLE BRACKET
909	PCAP33M	CAP SCREW M5-.8 X 12

REF	PART #	DESCRIPTION
910	PSB10270910	PIPE ELBOW 90 DEG 3/8 X 3/8 PT
911	PSB10270911	COOLANT VALVE ASSEMBLY
912	PSB10270912	COOLANT NOZZLE 3/8 X 30"
913	PSB10270913	PIPE ELBOW 90 DEG 3/8 PT X 1/2"
914	PSB10270914	COOLANT HOSE 1/2 X 59"
915	PSB10270915	HOSE CLAMP 3/4"
916	PSB10280916	SPLASH PAN
917	PCAP50M	CAP SCREW M5-.8 X 10
918	PW02M	FLAT WASHER 5MM

# Electrical Box & Control Panel



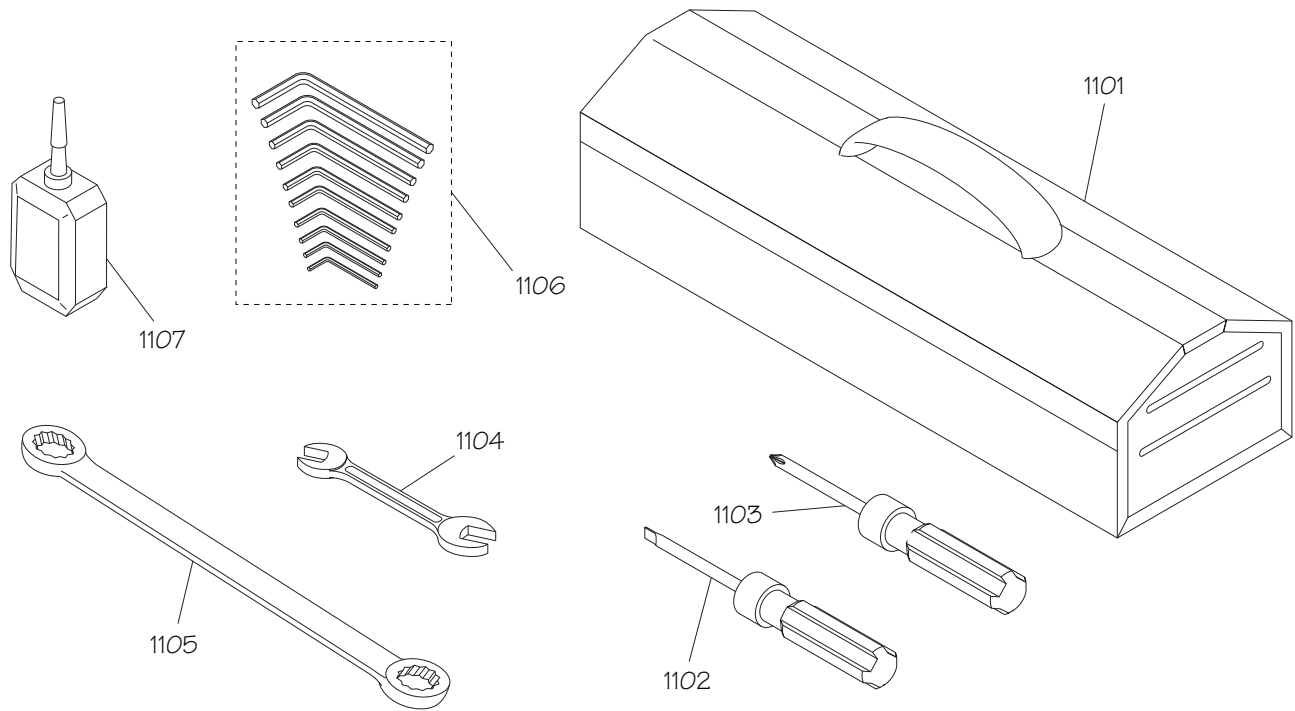
# Electrical Box & Control Panel Parts List

REF	PART #	DESCRIPTION
1001	PSB10281001	CONTACTOR AB 100-C16-400 24V
1002	PSB10281002	AUX CONTACTOR AB 100-F
1003	PSB10281003	CONTACTOR AB 100-C09-01 24V
1004	PSB10281004	CONTACTOR AB 100-C90-400 24V
1005	PSB10281005	BRAKE RESISTOR
1006	PC020B	CAPACITOR 20M 450V 1-3/4 X 2-3/8
1006-1	PSB10281006-1	CAPACITOR COVER
1007	PSB10281007	TRANSFORMER YUNG A009-0392 500V
1008	PSB10281008	RELAY OMRON MY4J 24V
1009	PSB10281009	RELAY SOCKET OMRON
1010	PSB10271003	FUSE HOLDER 3P
1011	PSB10281011	FUSE 30A
1012	PSB10271017	FUSE HOLDER 4P
1013	PSB10271016	FUSE 1A
1014	PSB10271013	FUSE 5A
1015	PSB10271014	FUSE 2A
1016	PSB10271013	FUSE 5A
1017	PSB10281017	INVERTER YASKAWA VS-606V7
1018	PSB10281018	ELECTRICAL CABINET W/DOOR ASSY
1019	PSB10281019	ELECTRICAL CABINET BACKBOARD
1020	PSB10281020	COOLING FAN ASSEMBLY

REF	PART #	DESCRIPTION
1021	PSB10281021	TERMINAL BLOCK ASSEMBLY
1022	PSB10281022	ELECTRICAL RECEPTACLE 110V
1023	PSB10281023	OL RELAY AB 193-TAB40-B 2.4-4.0A
1024	PSB10281024	OL RELAY AB 193-TAB10-B 0.6-1.0A
1025	PSB10281025	SPINDLE SPEED TACHOMETER
1026	PSB10281026	SPINDLE ON BUTTON
1027	PSB10281027	POWER ON BUTTON/LAMP
1028	PSB10281028	SPINDLE OFF BUTTON
1029	PSB10281029	SPINDLE DIRECTION SWITCH
1030	PSB10281030	Z-AXIS UP BUTTON
1031	PSB10281031	CONTROL PANEL
1032	PSB10281032	Z-AXIS DOWN BUTTON
1033	PSB10281033	EMERGENCY STOP BUTTON
1034	PSB10281034	COOLANT PUMP SWITCH
1035*	PSB10281035	CONTROL PANEL BOX
1036*	PSB10281036	CONTROL PANEL ARM ASSEMBLY
1037*	PSB10281037	CONTROL PANEL ARM JUNCTION BOX
1038*	PSB10281038	ARM ASSEMBLY LOCK KNOB ASSY
1039	PSB10271012	MAIN POWER SWITCH ASSEMBLY
1040	PSB10260986	SPINDLE SPEED DIAL

\*Not Shown

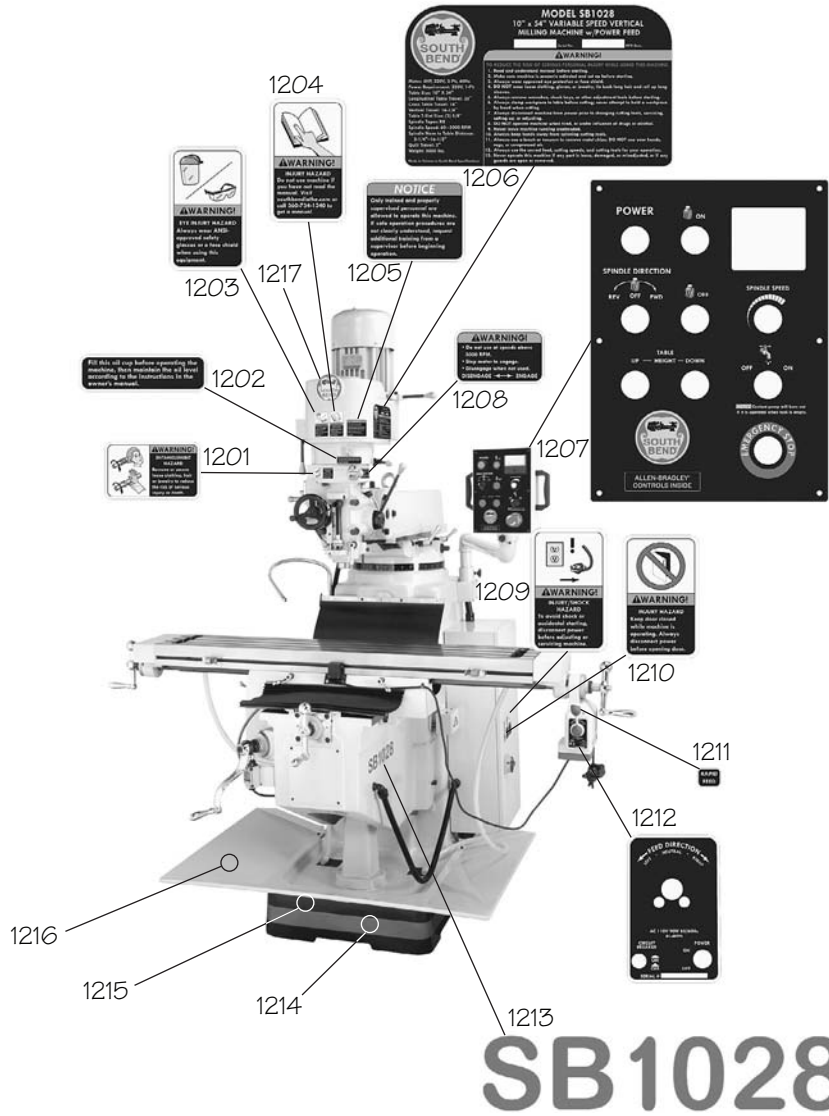
# Tools



REF	PART #	DESCRIPTION
1101	PSB10241004	TOOLBOX
1102	PSDF2	SCREWDRIVER FLAT #2
1103	PSDP2	PHLP HD SCREWDRIVER #2
1104	PWR1214	WRENCH 12/14MM

REF	PART #	DESCRIPTION
1105	PWR1921C	CLOSED WRENCH 19/21MM
1106	PAW1510M	HEX WRENCH 10PC 1.5-10 MM
1107	PSB10241007	BOTTLE FOR OIL

# Front Machine Labels



# SB1028

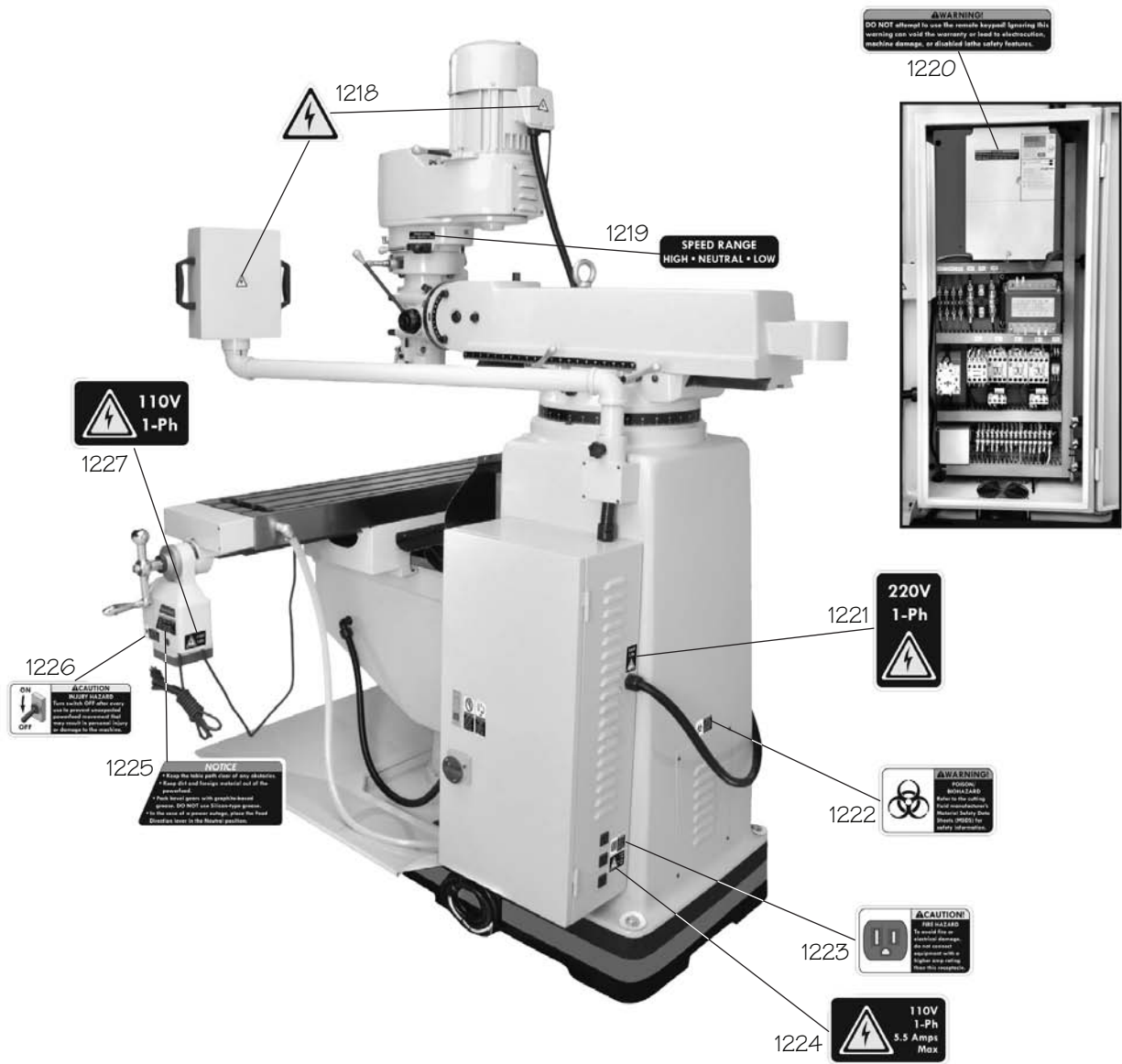
REF	PART #	DESCRIPTION
1201	PSBLABEL08HL	ENTANGLEMENT HAZARD LABEL
1202	PSB10271202	LUBRICATION DIRECTION LABEL
1203	PSBLABEL03HL	EYE INJURY HAZARD LABEL
1204	PSBLABEL01HL	READ MANUAL LABEL
1205	PSB10271205	TRAINED PERSONNEL NOTICE LABEL
1206	PSB10281206	MACHINE ID LABEL
1207	PSB10271207	CONTROL PANEL LABEL
1208	PSB10241105	DOWNFEED SELECTOR LABEL
1209	PSBLABEL02HL	DISCONNECT WARNING LABEL

REF	PART #	DESCRIPTION
1210	PSBLABEL13HL	CLOSE DOOR WARNING LABEL
1211	PSB10241113	RAPID FEED LABEL
1212	PSB10241114	POWER FEED CONTROL PANEL LABEL
1213	PSB10281213	MODEL NUMBER LABEL
1214	PSBPAINTO3	SB DARK BLUE TOUCH-UP PAINT
1215	PSBPAINTO2	SB LIGHT BLUE TOUCH-UP PAINT
1216	PSBPAINTO1	SB GRAY TOUCH-UP PAINT
1217	SB1319	SB NAMEPLATE 90MM

## ⚠ WARNING

The safety labels provided with your machine are used to make the operator aware of the machine hazards and ways to prevent injury. The owner of this machine **MUST** maintain the original location and readability of these safety labels. If any label is removed or becomes unreadable, **REPLACE** that label before using the machine again. Contact South Bend Lathe Co. at (360) 734-1540 or [www.southbendlathe.com](http://www.southbendlathe.com) to order new labels.

# Side & Rear Machine Labels



REF	PART #	DESCRIPTION
1218	PSBLABEL15L	ELECTRICITY LABEL
1219	PSB10271220	SPEED RANGE LABEL
1220	PSB10281220	INVERTER WARNING LABEL
1221	PSB10271221	220V 1PH LABEL
1222	PSBLABELO6HL	BIOHAZARD WARNING LABEL

REF	PART #	DESCRIPTION
1223	PSB10241119	110V OUTLET CAUTION LABEL
1224	PSB10281223	110V 1PH OUTLET LABEL
1225	PSB10241115	POWER FEED NOTICE LABEL
1226	PSB10241112	POWER FEED CAUTION LABEL
1227	PSB10241116	110V 1PH POWER FEED LABEL

---

## WARRANTY

---

This quality product is warranted by South Bend Lathe Company to the original buyer for one year from the date of purchase. This warranty does not apply to consumable parts, or defects due to any kind of misuse, abuse, negligence, accidents, repairs, alterations or lack of maintenance. We do not reimburse for third party repairs. In no event shall we be liable for death, injuries to persons or property, or for incidental, contingent, special or consequential damages arising from the use of our products.

We do not warrant or represent that this machine complies with the provisions of any law, act, code, regulation, or standard of any domestic or foreign government, industry, or authority. In no event shall South Bend's liability under this warranty exceed the original purchase price paid for this machine. Any legal actions brought against South Bend Lathe Company shall be tried in the State of Washington, County of Whatcom.

This is the sole written warranty for this machine. Any and all warranties that may be implied by law, including any merchantability or fitness, for any purpose, are hereby limited to the duration of this warranty. To take advantage of this warranty, contact us by mail or phone to give us the details of the problem you are having.

Thank you for your business and continued support.



South Bend Lathe Co.  
P.O. Box 2027  
Bellingham, WA 98227

PHONE: (360) 734-1540 (Administrative Offices)

FAX: (360) 676-1075 (International)

FAX: (360) 734-1639 (USA only)

[southbendlathe.com](http://southbendlathe.com)

